



PADMAWATI
EXTRUSION

CATALOGUE 2019

SOLAR SECTIONS

Padmawati Extrusion Pvt. Ltd., with over 2 decades of experience, with focus on customer need and commitment to **quality, perfection and innovation**, has become one of the leading nationwide providers of aluminium.

The company has been engaged in the complete process of extrusion, from technical sales advise, designing, testing to providing all ancillary, hardware fittings for system windows, glazing systems, exhibition systems and various products and caters to architects, contractors and designers from different sectors & industries.

With an eye on quality, the company has also introduced **aluminium profiles with scratch free sand blasted anodize finish, brush anodize finish, mirror finish and various powder coated finishes** for our discerning customers.

Our way of working reflects delivering an advantage in every key aspect of our business – sourcing, operations and cost. Basically, we are a **one stop shop for extruded aluminium** custom solutions for practically any application.





SOLAR SECTIONS

Section No 1401

Wt/Mtr 0.280 Kg

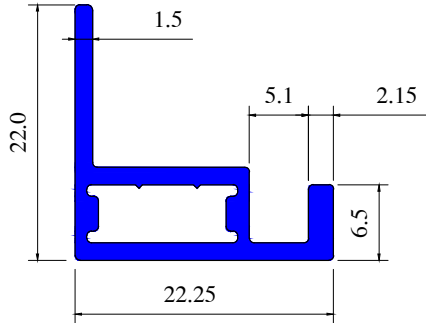

Section No 1405

Wt/Mtr 0.276 Kg

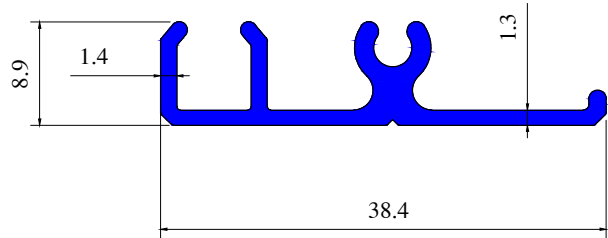

Section No 1402

Wt/Mtr 0.408 Kg

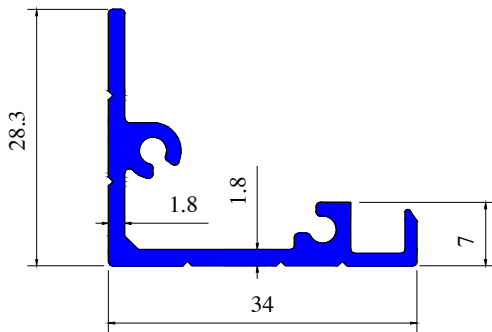

Section No 1406

Wt/Mtr 0.680 Kg

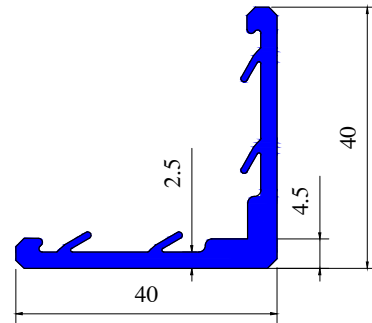

Section No 1403

Wt/Mtr 0.216 Kg

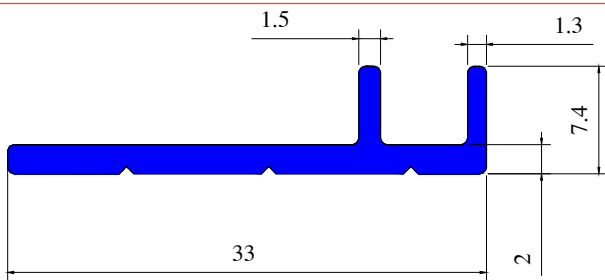

Section No 1407

Wt/Mtr 0.232 Kg

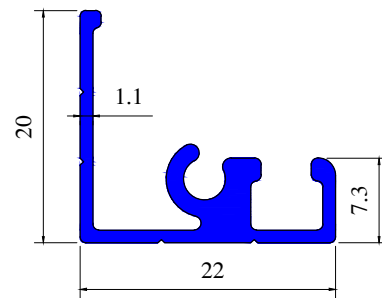

Section No 1404

Wt/Mtr 0.262 Kg

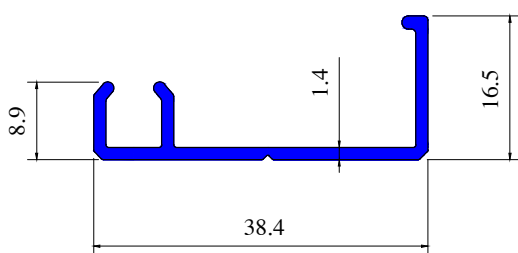

Section No 1408

Wt/Mtr 0.110 Kg

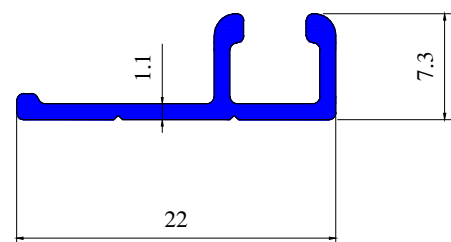



SOLAR SECTIONS

Section No 1409

Wt/Mtr 0.824 Kg

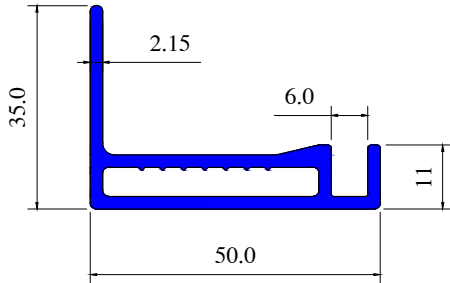

Section No 1415

Wt/Mtr 0.306 Kg

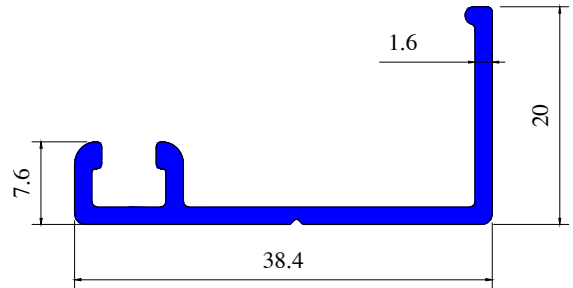

Section No 1410

Wt/Mtr 0.651 Kg

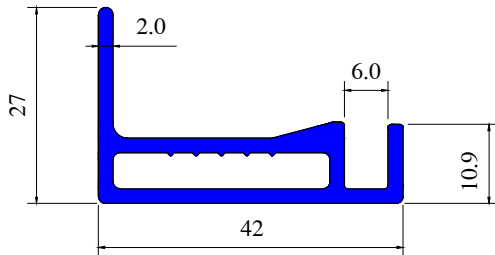

Section No 1418

Wt/Mtr 0.964 Kg

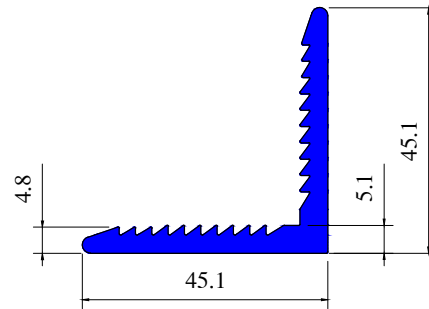

Section No 1413

Wt/Mtr 0.370 Kg

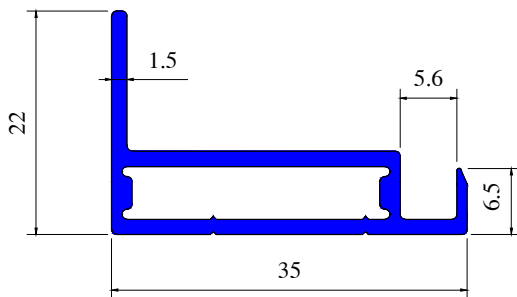

Section No 1419

Wt/Mtr 0.651 Kg

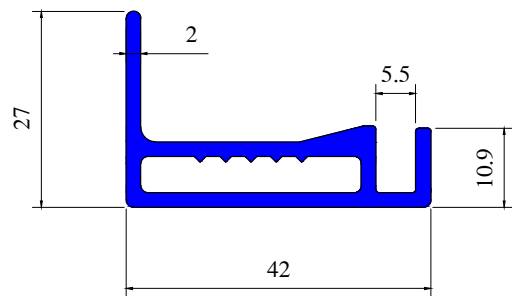

Section No 1414

Wt/Mtr 0.689 Kg

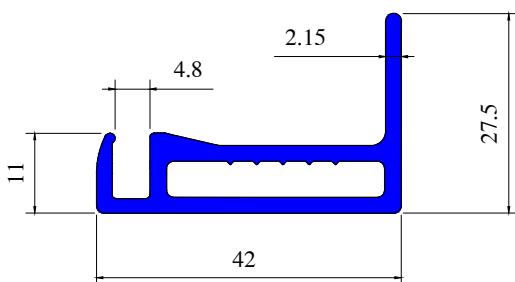

Section No 1420

Wt/Mtr 0.405 Kg

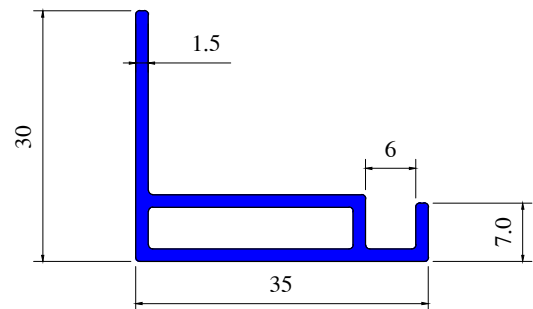



SOLAR SECTIONS

Section No 1422

Wt/Mtr 0.408 Kg

Section No 1432

Wt/Mtr 0.213 Kg

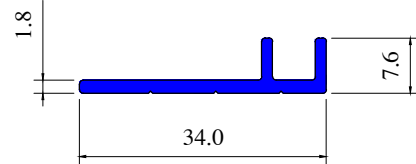
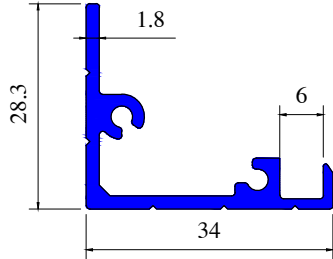

Section No 1429

Wt/Mtr 0.378 Kg

Section No 1437

Wt/Mtr 0.370 Kg

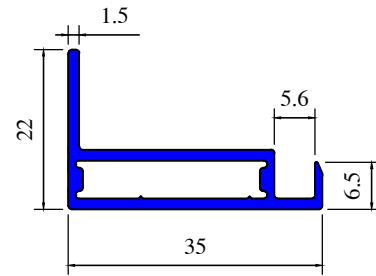
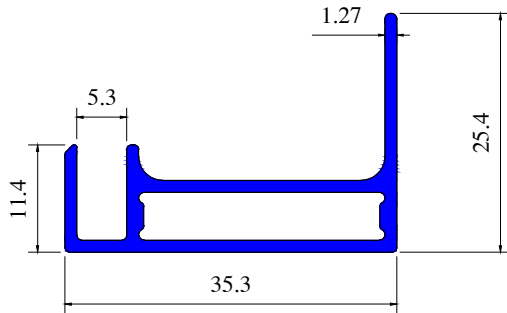

Section No 1430

Wt/Mtr 0.346 Kg

Section No 1438

Wt/Mtr 0.302 Kg

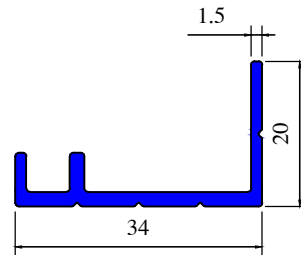
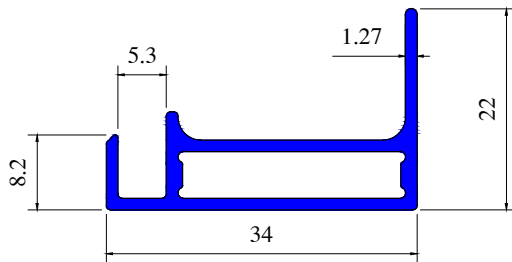

Section No 1431

Wt/Mtr 0.392 Kg

Section No 1439

Wt/Mtr 0.659 Kg

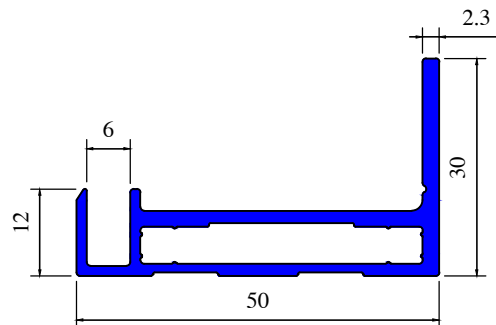
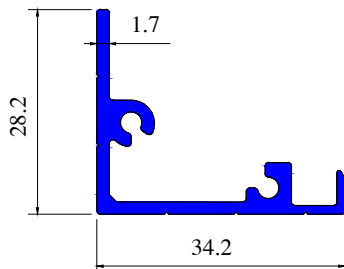

SOLAR SECTIONS

Section No 1440

Wt/Mtr 0.526 Kg

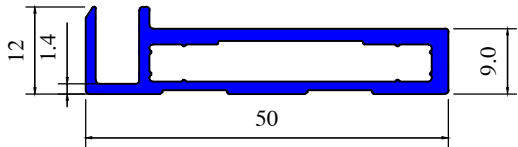

Section No 1445

Wt/Mtr 0.346 Kg

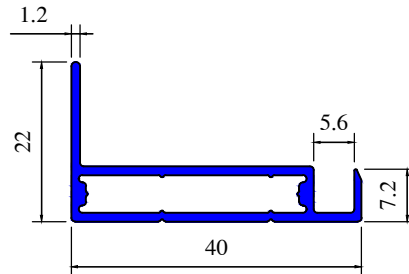

Section No 1441

Wt/Mtr 0.572 Kg

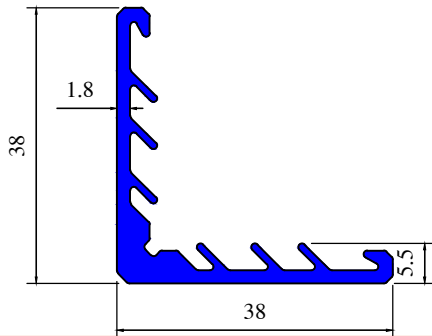

Section No 1447

Wt/Mtr 0.335 Kg

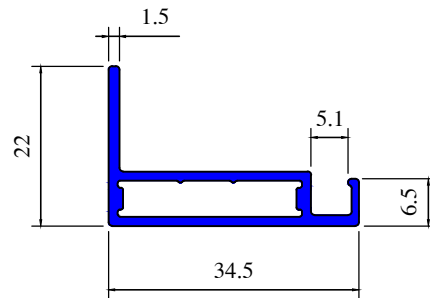

Section No 1442

Wt/Mtr 0.410 Kg

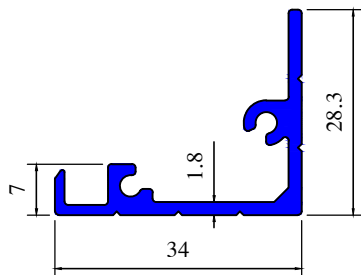

Section No 1448

Wt/Mtr 0.572 Kg

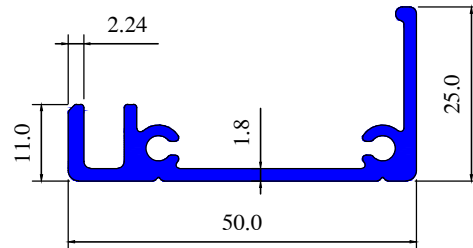

Section No 1443

Wt/Mtr 0.589 Kg

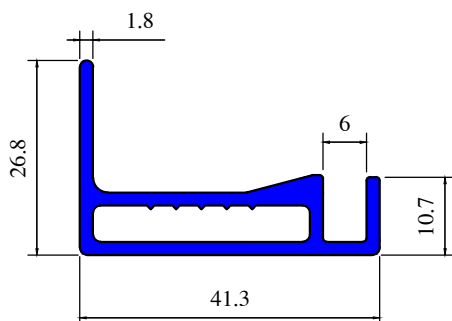

Section No 1449

Wt/Mtr 0.343 Kg

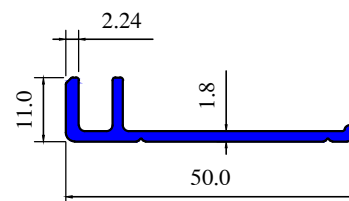



SOLAR SECTIONS

Section No 1450

Wt/Mtr 0.365 Kg

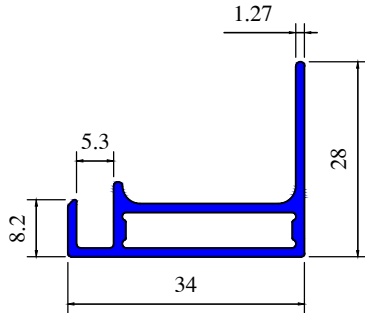

Section No 1454

Wt/Mtr 0.284 Kg

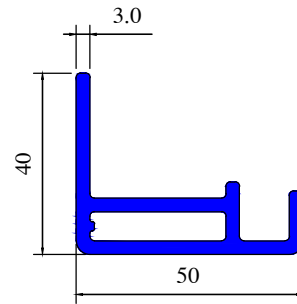

Section No 1451

Wt/Mtr 0.767 Kg

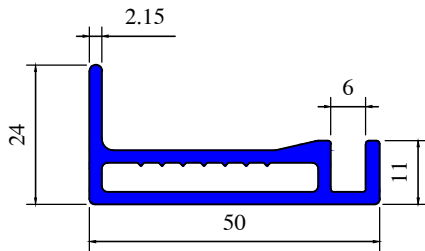

Section No 1455

Wt/Mtr 0.313 Kg

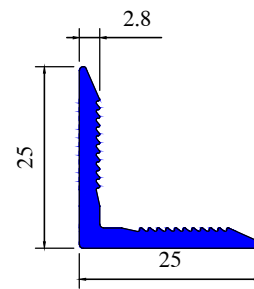

Section No 1452

Wt/Mtr 0.643 Kg

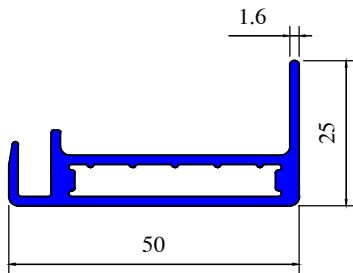

Section No 1456

Wt/Mtr 0.661 Kg

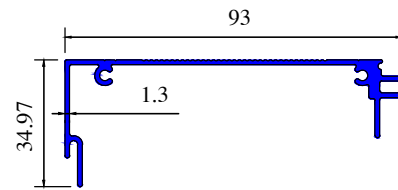

Section No 1453

Wt/Mtr 2.433 Kg

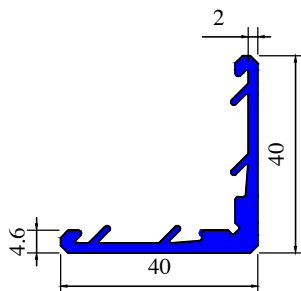

Section No 1457

Wt/Mtr 0.119 Kg

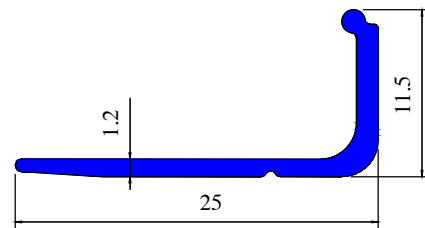



SOLAR SECTIONS

Section No 1458

Wt/Mtr 0.551 Kg

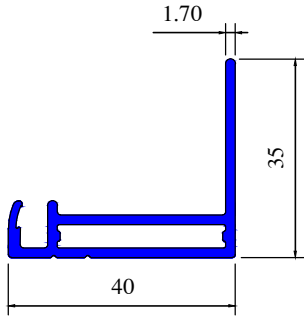

Section No 1462

Wt/Mtr 0.567 Kg

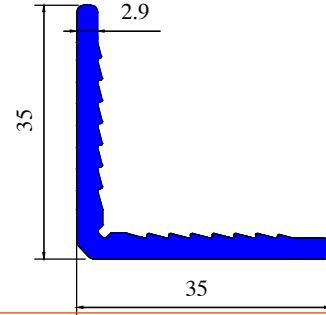

Section No 1459

Wt/Mtr 0.721 Kg

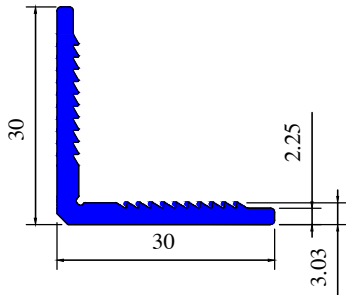

Section No 1463

Wt/Mtr 0.219 Kg

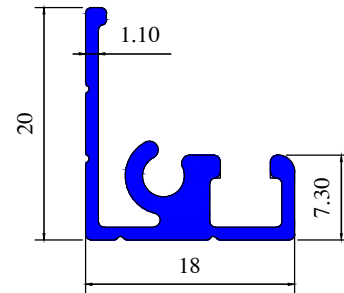

Section No 1460

Wt/Mtr 0.305 Kg

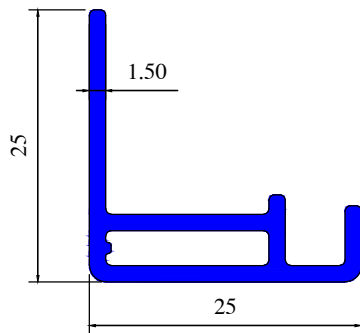

Section No 1464

Wt/Mtr 0.097 Kg

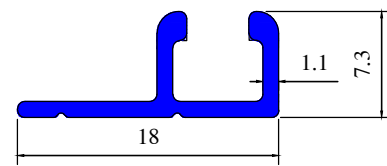

Section No 1461

Wt/Mtr 0.154 Kg

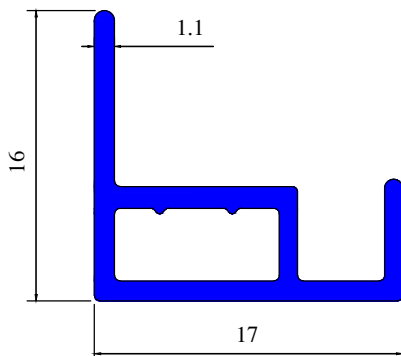

Section No 1466

Wt/Mtr 0.294 Kg

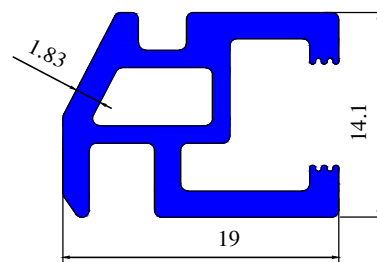



SOLAR SECTIONS

Section No 1467

Wt/Mtr 0.486 Kg

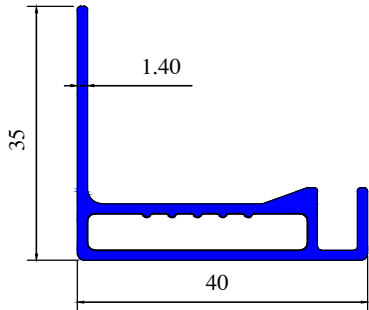

Section No 1471

Wt/Mtr 0.459 Kg

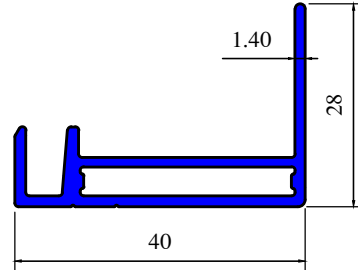

Section No 1468

Wt/Mtr 0.367 Kg

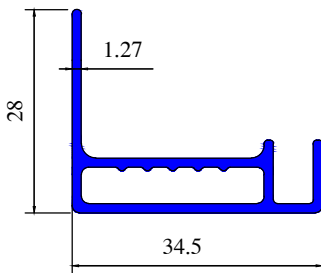

Section No 1472

Wt/Mtr 0.478 Kg

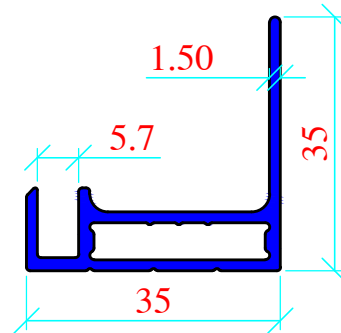

Section No 1469

Wt/Mtr 0.659 Kg

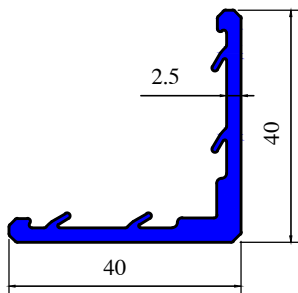

Section No 1473

Wt/Mtr 0.459 Kg

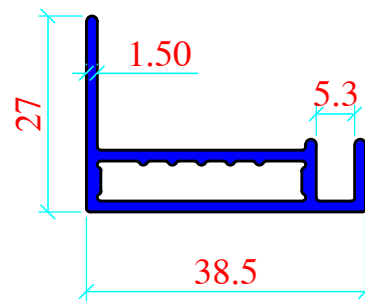

Section No 1470

Wt/Mtr 0.490 Kg

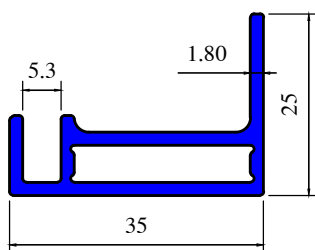

Section No 1474

Wt/Mtr 0.380 Kg

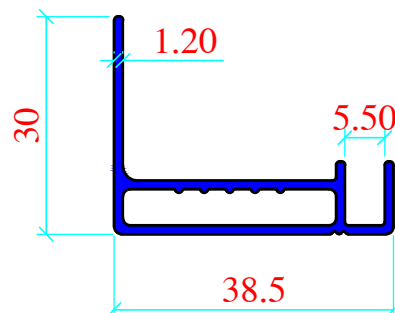



SOLAR SECTIONS

Section No 1178

Wt/Mtr 1.927 Kg

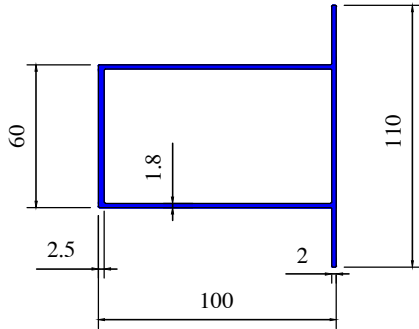



PADMAWATI EXTRUSION PVT. LTD.

5/2, Bharat Ashish Building, D.B. Gupta Road, Paharganj, New Delhi - 110055 (India)
+91 98999 07895, 98112 76191 | Email : info@padmawatiextrusion.com