



PADMAWATI
EXTRUSION

CATALOGUE 2019

INDUSTRIAL SECTIONS

Padmawati Extrusion Pvt. Ltd., with over 2 decades of experience, with focus on customer need and commitment to **quality, perfection and innovation**, has become one of the leading nationwide providers of aluminium.

The company has been engaged in the complete process of extrusion, from technical sales advise, designing, testing to providing all ancillary, hardware fittings for system windows, glazing systems, exhibition systems and various products and caters to architects, contractors and designers from different sectors & industries.

With an eye on quality, the company has also introduced **aluminium profiles with scratch free sand blasted anodize finish, brush anodize finish, mirror finish and various powder coated finishes** for our discerning customers.

Our way of working reflects delivering an advantage in every key aspect of our business – sourcing, operations and cost. Basically, we are a **one stop shop for extruded aluminium** custom solutions for practically any application.





INDUSTRIAL SECTIONS

Section No 1190

Wt/Mtr 1.360 Kg

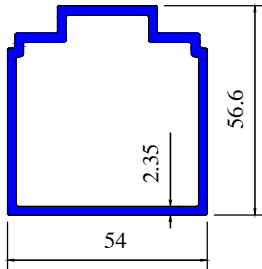

Section No 1139

Wt/Mtr 0.297 Kg

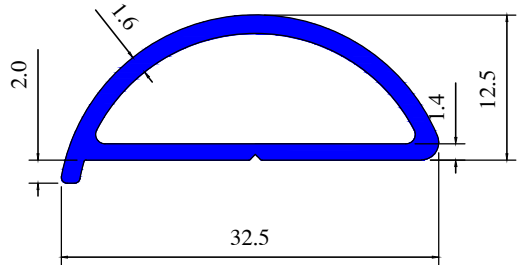

Section No 1129

Wt/Mtr 0.338 Kg

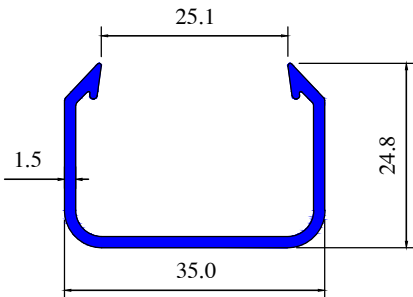

Section No 1618

Wt/Mtr 0.518 Kg

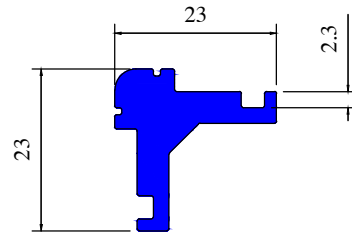

Section No 1531

Wt/Mtr 3.78 Kg

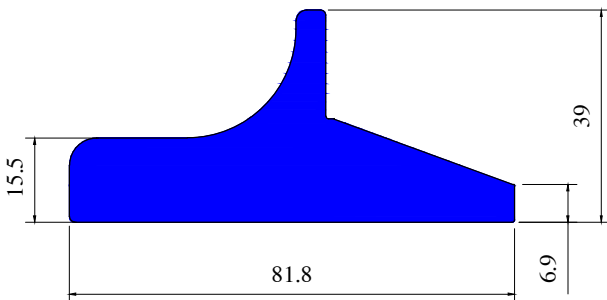

Section No 1544

Wt/Mtr 0.977 Kg

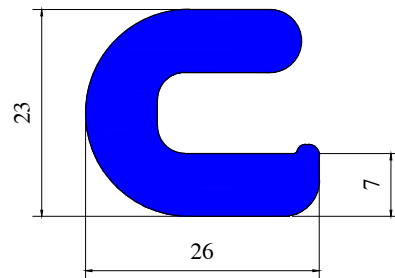

Section No 1111

Wt/Mtr 1.458 Kg

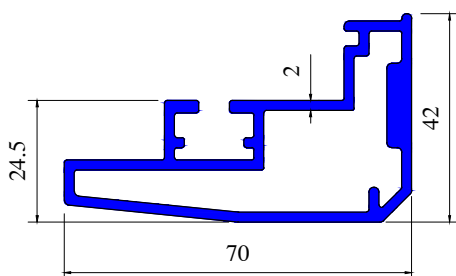

Section No 1110

Wt/Mtr 2.687 Kg

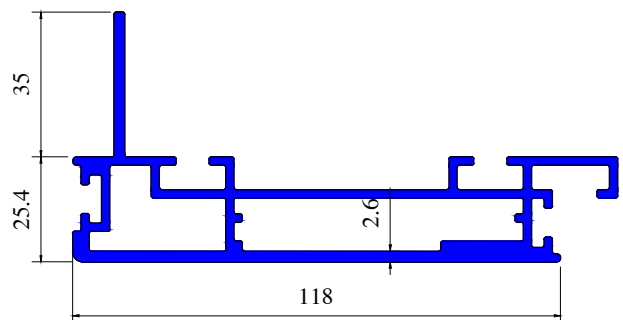

PADMAWATI EXTRUSION PVT. LTD.

REG. OFF: 5/2, BHARAT ASHISH BUILDING D.B GUPTA ROAD, PAHARGANG, DELHI-110055
PH: 011-23219291, 23239291 E-mail: info@padmawatiextrusion.com URL: padmawatiextrusion.com



INDUSTRIAL SECTIONS

Section No 1108

Wt/Mtr 0.880 Kg

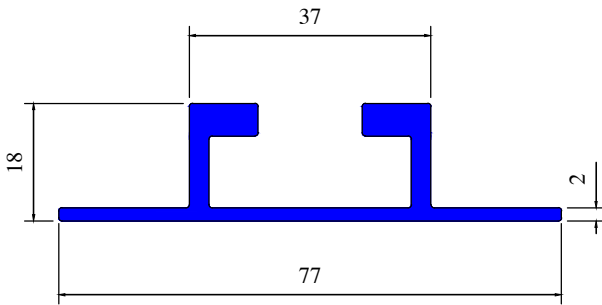

Section No 1134

Wt/Mtr 0.982 Kg

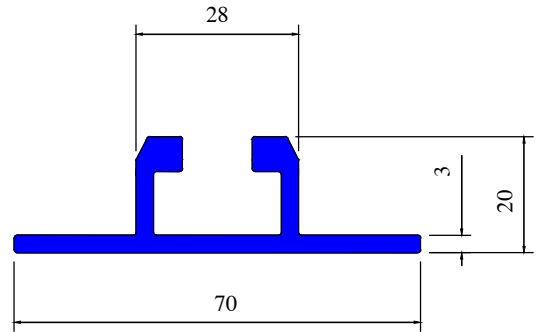

Section No 1115

Wt/Mtr 0.810 Kg

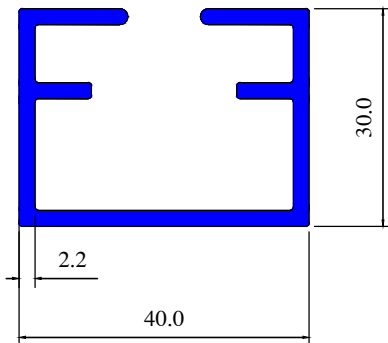

Section No 1106

Wt/Mtr 0.683 Kg

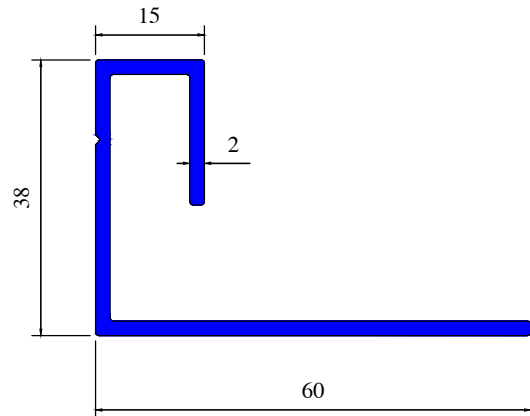

Section No 1133

Wt/Mtr 2.548 Kg

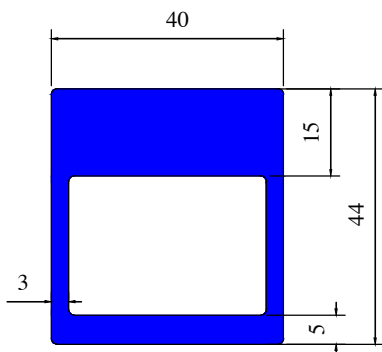

Section No 1107

Wt/Mtr 0.540 Kg

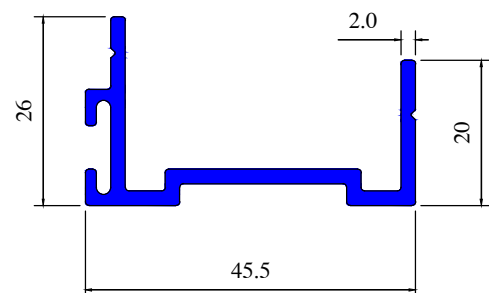



INDUSTRIAL SECTIONS

Section No 1537

Wt/Mtr 0.516 Kg

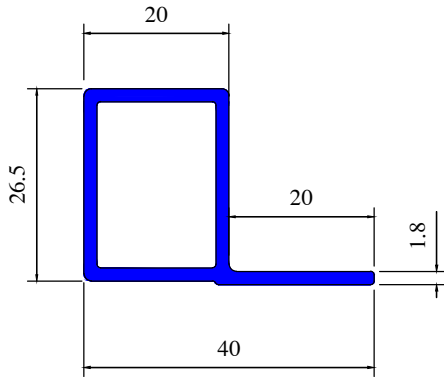

Section No 1116

Wt/Mtr 0.894 Kg

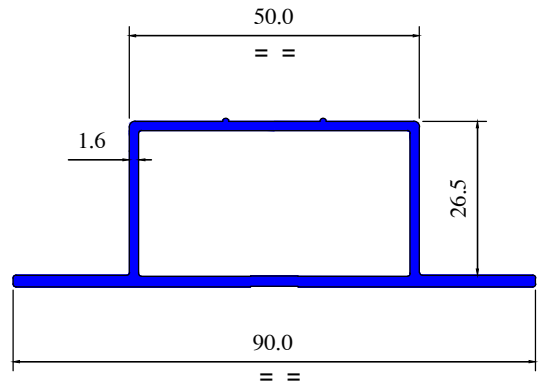

Section No 1510

Wt/Mtr 0.547 Kg

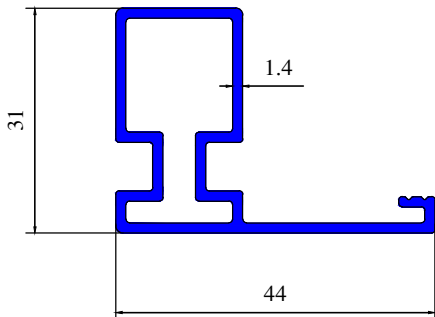

Section No 1117

Wt/Mtr 0.953 Kg

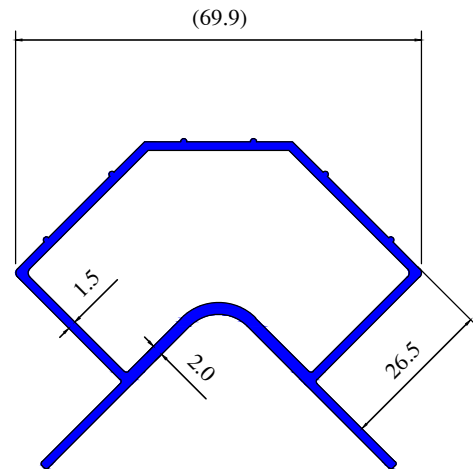

Section No 1541

Wt/Mtr 0.200 Kg

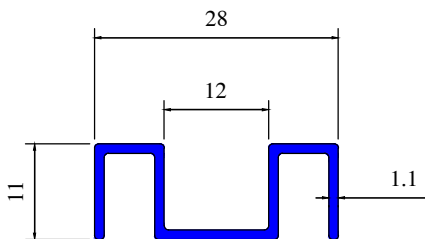

Section No 1118

Wt/Mtr 0.259 Kg

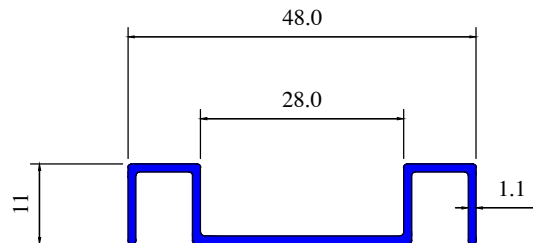



INDUSTRIAL SECTIONS

Section No 1121

Wt/Mtr 0.126 Kg

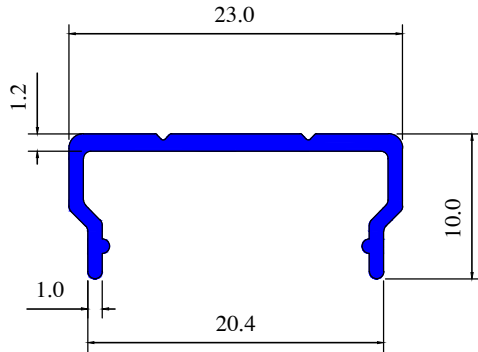

Section No 1122

Wt/Mtr 0.370 Kg

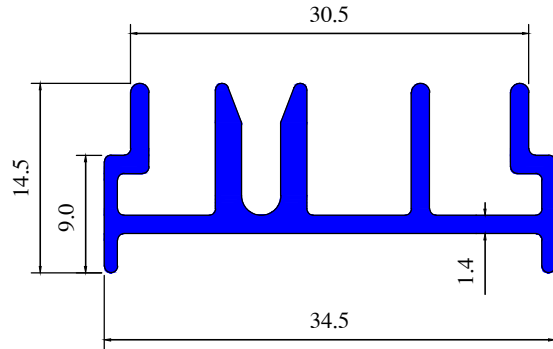

Section No 1123

Wt/Mtr 0.338 Kg

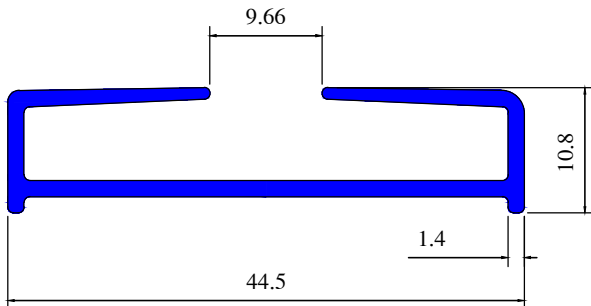

Section No 1124

Wt/Mtr 2.565 Kg

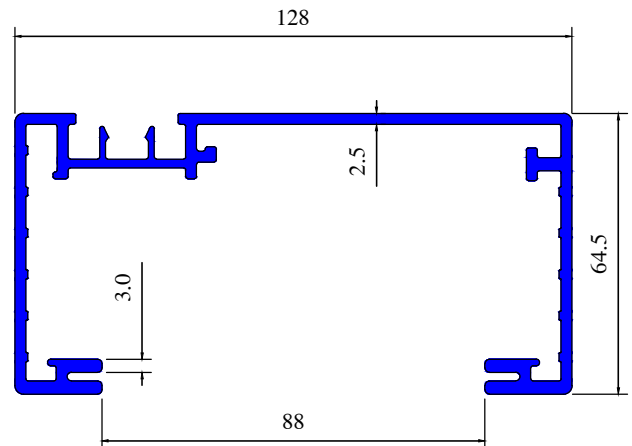

Section No 1125

Wt/Mtr 0.127 Kg

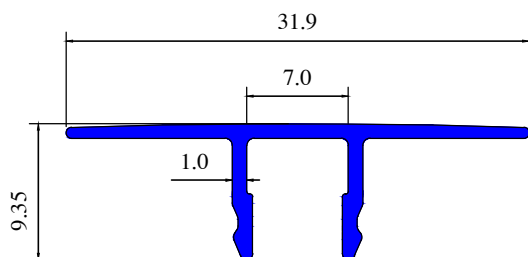

Section No 1109

Wt/Mtr 1.401 Kg

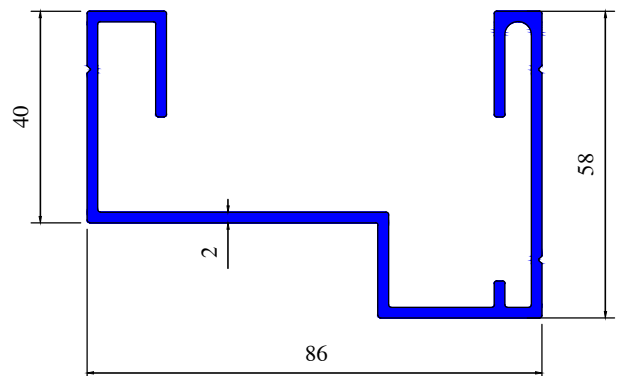



INDUSTRIAL SECTIONS

Section No 1602

Wt/Mtr 0.753 Kg

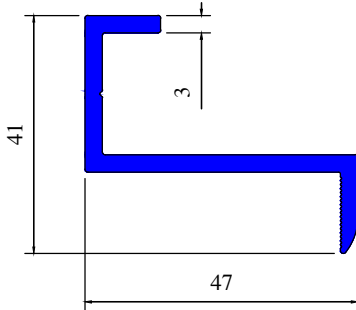

Section No 1598

Wt/Mtr 0.530 Kg

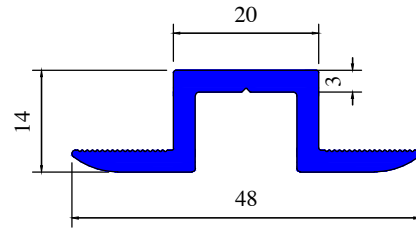

Section No 1599

Wt/Mtr 0.421 Kg

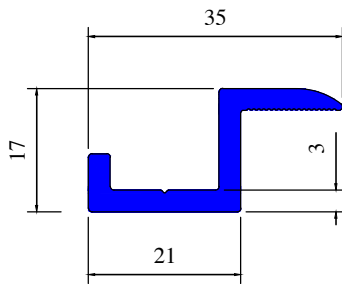

Section No 1594

Wt/Mtr 0.883 Kg

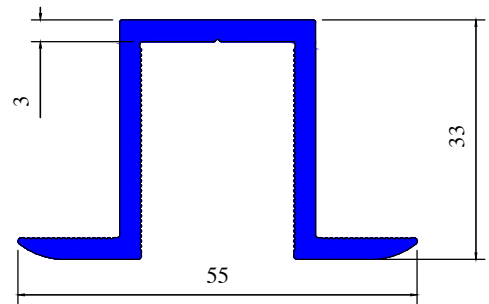

Section No 1595

Wt/Mtr 0.785 Kg

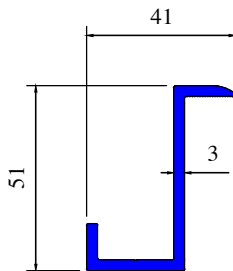

Section No 1592

Wt/Mtr 0.578 Kg

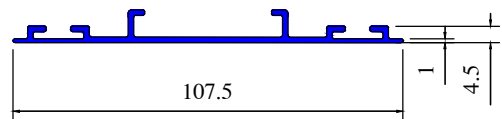

Section No 1606

Wt/Mtr 0.124 Kg

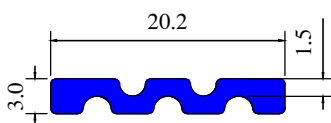

Section No 1593

Wt/Mtr 0.332 Kg

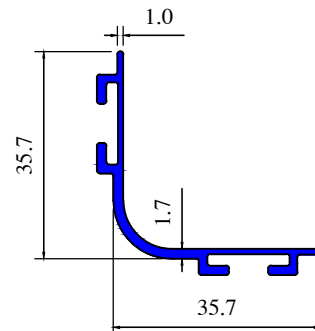



INDUSTRIAL SECTIONS

Section No 1519

Wt/Mtr 2.13 Kg

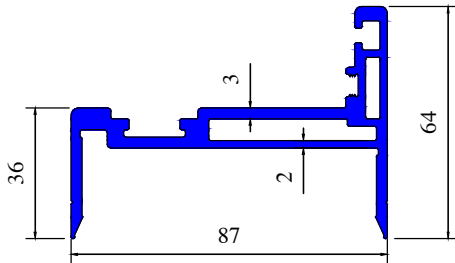

Section No 1520

Wt/Mtr 2.43 Kg

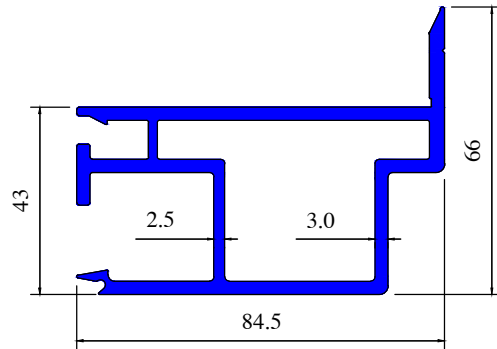

Section No 1135

Wt/Mtr 2.832 Kg

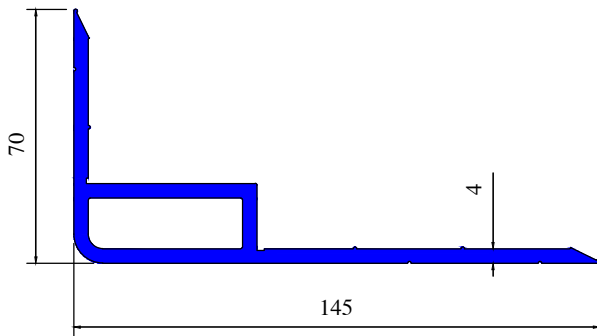

Section No 1136

Wt/Mtr 1.742 Kg

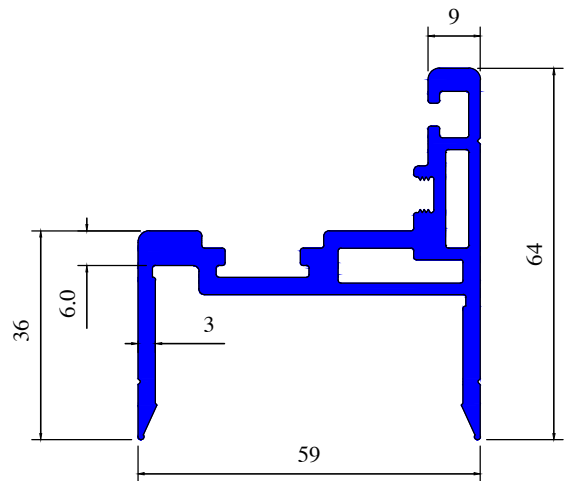

Section No 1137

Wt/Mtr 1.823 Kg

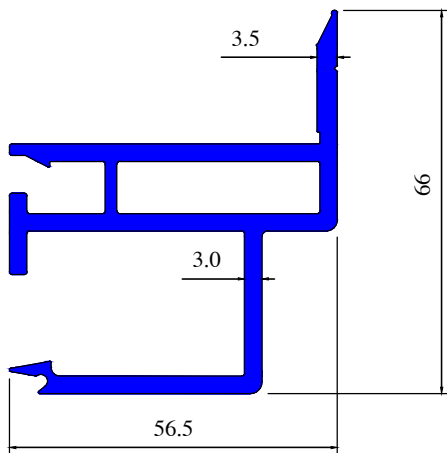

Section No 1138

Wt/Mtr 0.640 Kg

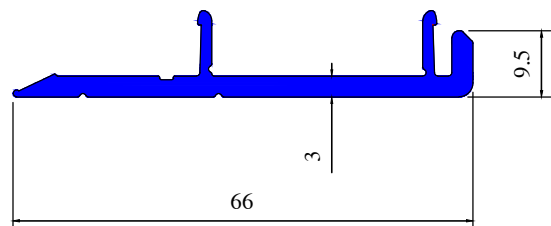



INDUSTRIAL SECTIONS

Section No 1152

Wt/Mtr 1.375 Kg

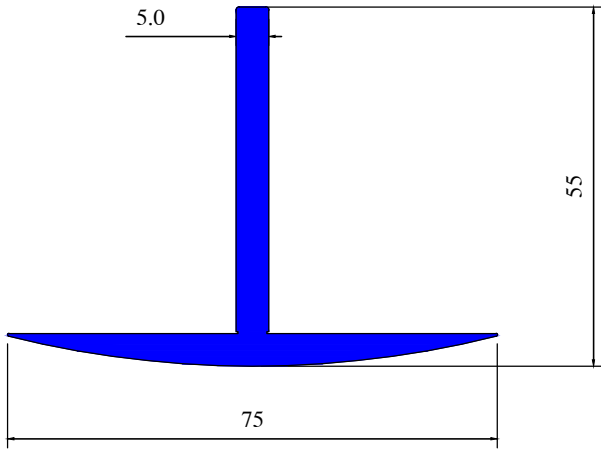

Section No 1162

Wt/Mtr 2.119 Kg

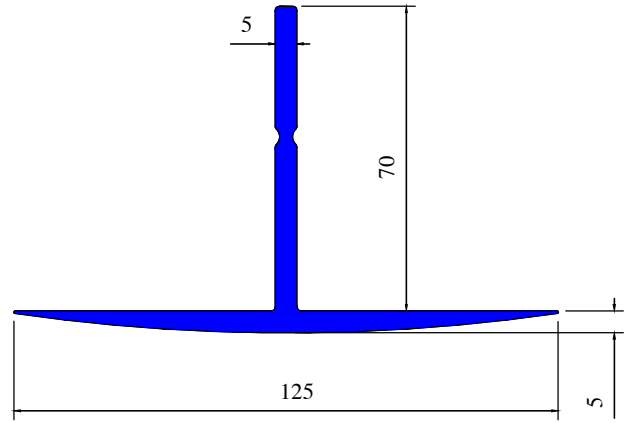

Section No 1177

Wt/Mtr 0.145 Kg

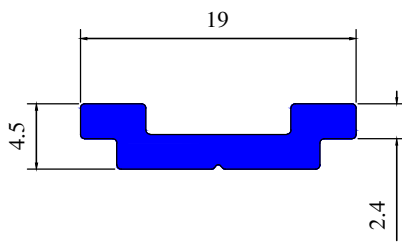

Section No 1586

Wt/Mtr 0.400 Kg

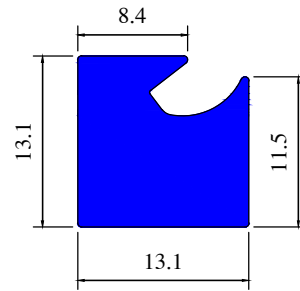

Section No 1540

Wt/Mtr 0.078 Kg

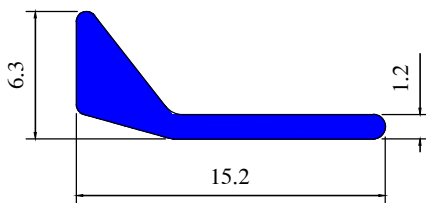

Section No 1596

Wt/Mtr 0.175 Kg

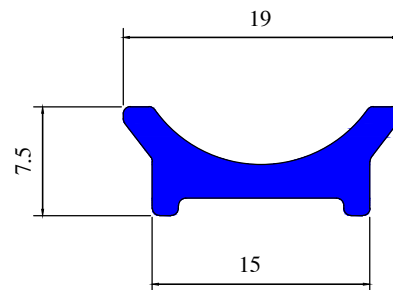

Section No 1597

Wt/Mtr 0.165 Kg

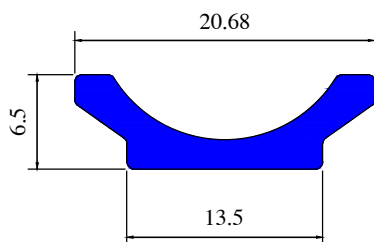

Section No 1588

Wt/Mtr 0.232 Kg

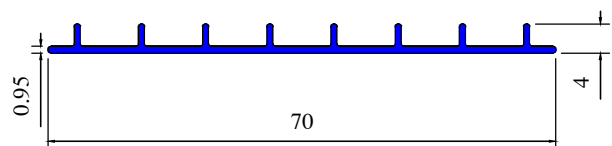



INDUSTRIAL SECTIONS

Section No 1660

Wt/Mtr 2.96 Kg

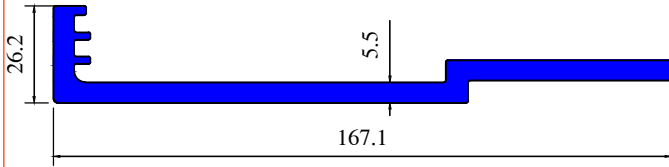

Section No 1662

Wt/Mtr 1.798 Kg

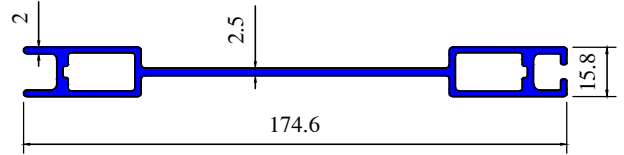

Section No 1680

Wt/Mtr 0.103 Kg

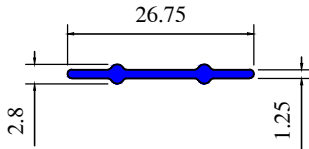

Section No 1688

Wt/Mtr 0.378 Kg

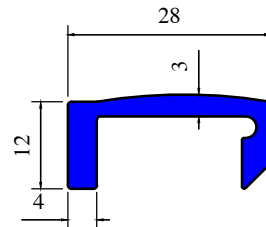

Section No 1690

Wt/Mtr 0.667 Kg

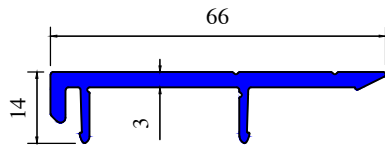

Section No 1691

Wt/Mtr 1.928 Kg

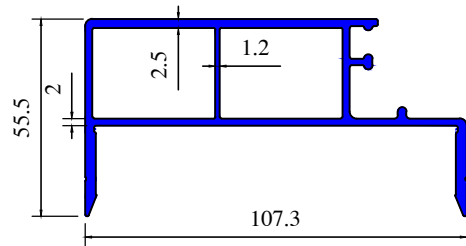

Section No 1692

Wt/Mtr 2.403 Kg

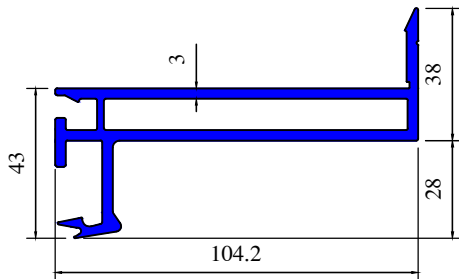

Section No 1655

Wt/Mtr 0.251 Kg

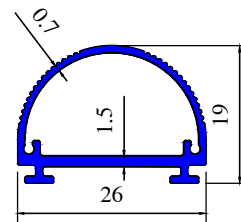

Section No 1687

Wt/Mtr 0.224 Kg

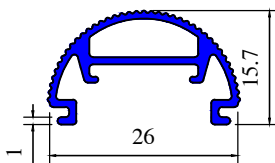



INDUSTRIAL SECTIONS

Section Nb 1707

Vt/Mtr 0.691 Kg

Section Nb 1721

Vt/Mtr 0.311 Kg

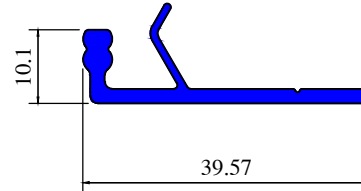
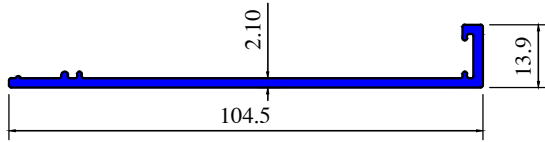

Section Nb 1712

Vt/Mtr 1.855 Kg

Section Nb 1724

Vt/Mtr 0.348 Kg

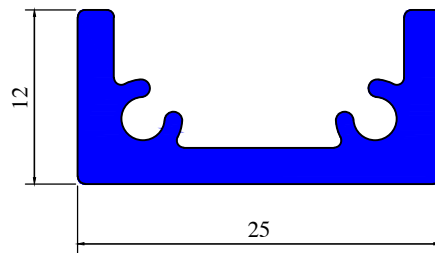
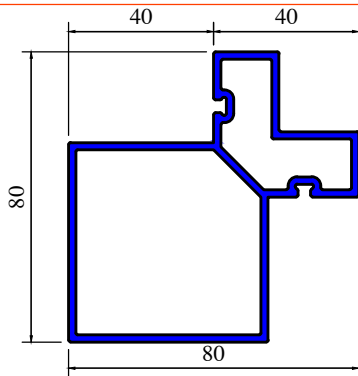

Section Nb 1713

Vt/Mtr 6.483 Kg

Section Nb 1725

Vt/Mtr 1.118 Kg

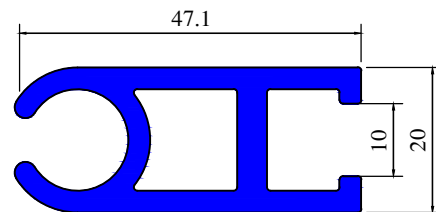
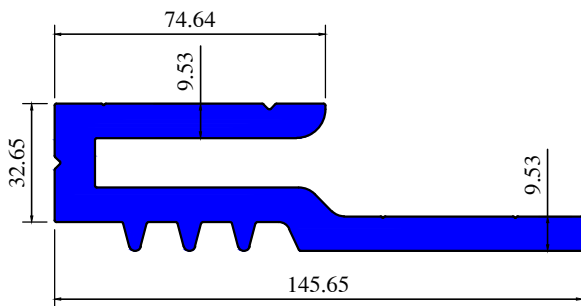

Section Nb 1714

Vt/Mtr 0.535 Kg

Section Nb 1726

Vt/Mtr 0.840 Kg

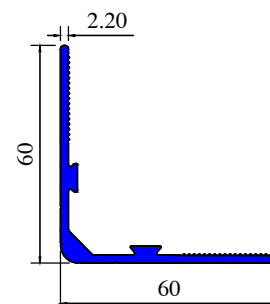
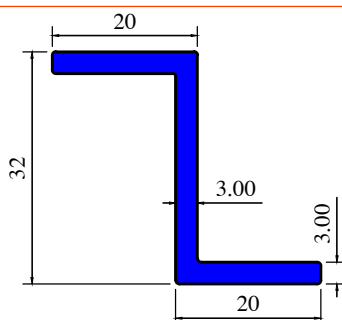

PADMAWATI EXTRUSION PVT. LTD.

REG. OFF: 5/2, BHARAT ASHISH BUILDING D.B GUPTA ROAD, PAHARGANG, DELHI-110055
PH: 011-23219291, 23239291 E-mail: info@padmawatiextrusion.com URL: padmawatiextrusion.com



INDUSTRIAL SECTIONS

Section Nb 1727

Vt/Mtr 1.034 Kg

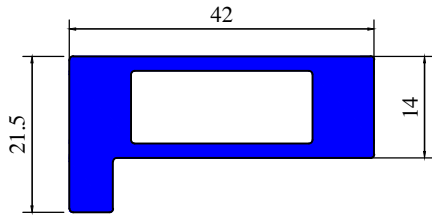

Section Nb 1737

Vt/Mtr 1.439 Kg

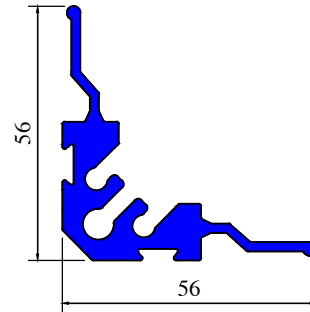

Section Nb 1728

Vt/Mtr 0.230 Kg

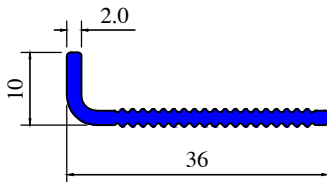

Section Nb 1738

Vt/Mtr 1.366 Kg

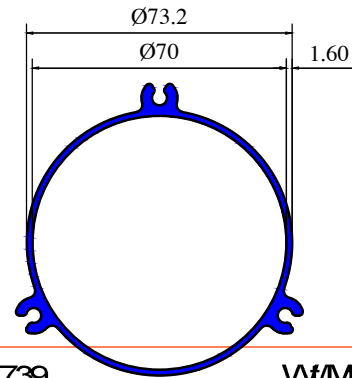

Section Nb 1729

Vt/Mtr 0.896 Kg

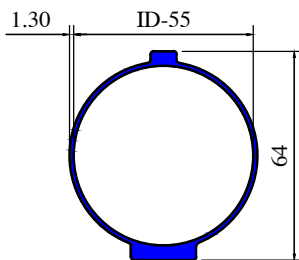

Section Nb 1739

Vt/Mtr 1.698 Kg

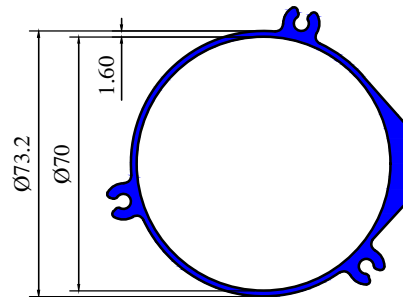

Section Nb 1730

Vt/Mtr 2.325 Kg

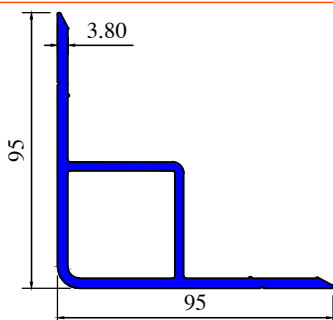

Section Nb 1740

Vt/Mtr 1.485 Kg

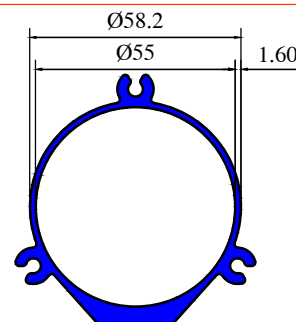

PADMAWATI EXTRUSION PVT. LTD.

REG. OFF: 5/2, BHARAT ASHISH BULDING D.B GUPTA ROAD, PAHARGANG, DELHI-110055
PH: 011-23219291, 23239291 E-mail: info@padmawatiextrusion.com URL: padmawatiextrusion.com



INDUSTRIAL SECTIONS

Section Nb 1741

Wt/Mtr 0.184 Kg

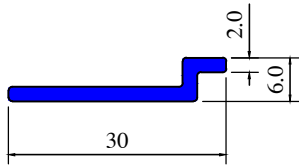

Section Nb 1762

Wt/Mtr 2.381 Kg

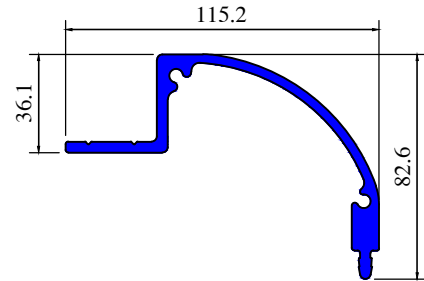

Section Nb 1750

Wt/Mtr 0.346 Kg

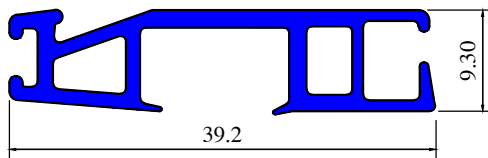

Section Nb 1763

Wt/Mtr 3.796 Kg

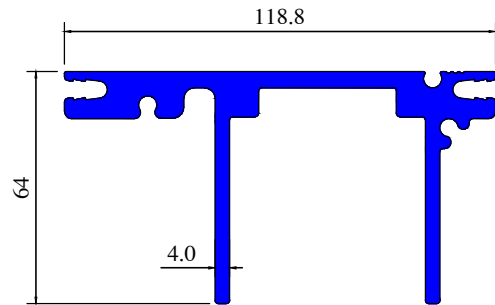

Section Nb 1757

Wt/Mtr 3.140 Kg

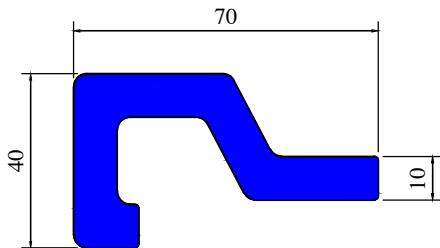

Section Nb 1764

Wt/Mtr 2.740 Kg

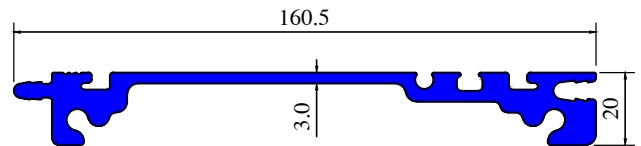

Section Nb 1761

Wt/Mtr 6.364 Kg

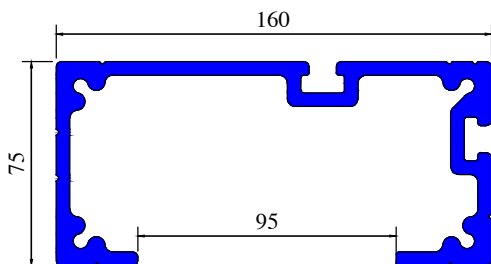

Section Nb 1765

Wt/Mtr 11.367 Kg

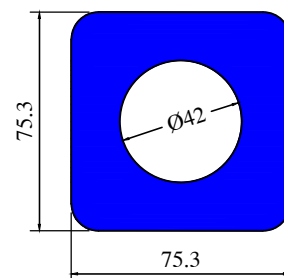



INDUSTRIAL SECTIONS

Section Nb 1766

Vt/Mtr 8.411 Kg

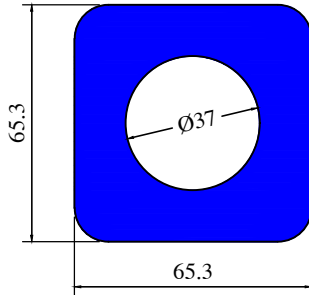

Section Nb 1786

Vt/Mtr 0.286 Kg

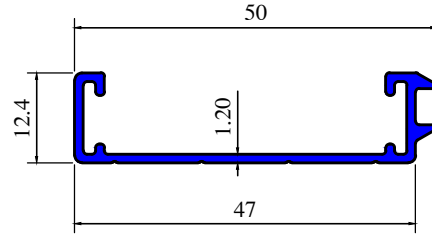

Section Nb 1769

Vt/Mtr 0.818 Kg

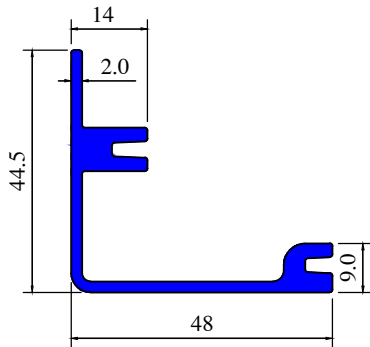

Section Nb 1788

Vt/Mtr 0.599 Kg

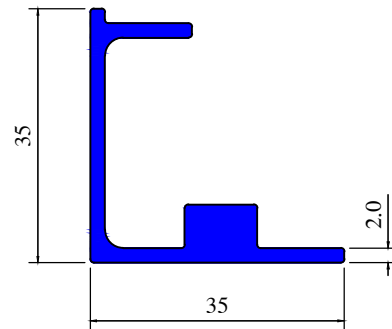

Section Nb 1770

Vt/Mtr 0.753 Kg

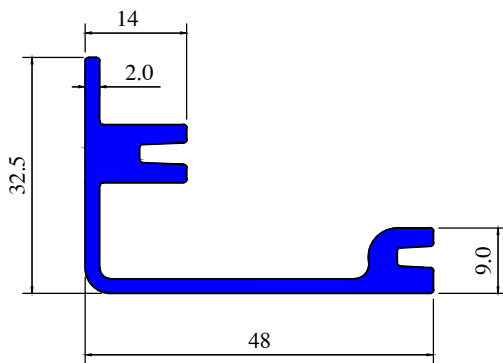

Section Nb 1793

Vt/Mtr 0.378 Kg

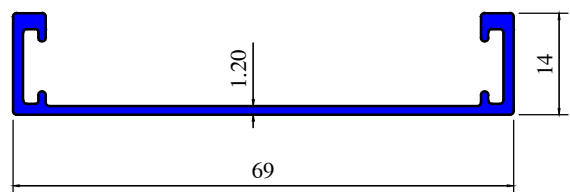

Section Nb 1784

Vt/Mtr 3.912 Kg

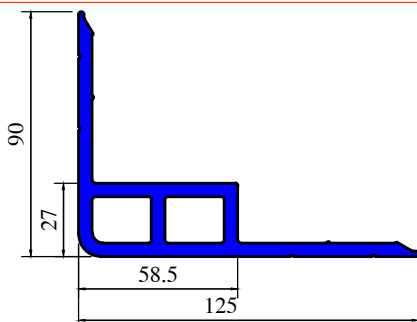

Section Nb 1794

Vt/Mtr 0.400 Kg

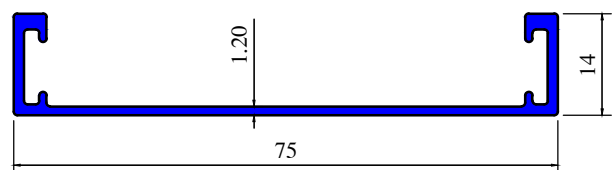

PADMAWATI EXTRUSION PVT. LTD.

REG. OFF: 5/2, BHARAT ASHISH BUILDING D.B GUPTA ROAD, PAHARGANG, DELHI-110055
PH: 011-23219291, 23239291 E-mail: info@padmawatiextrusion.com URL: padmawatiextrusion.com



INDUSTRIAL SECTIONS

Section Nb 1901

Vt/Mtr 0.580 Kg

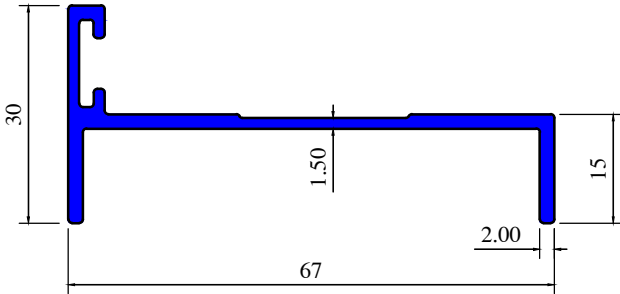

Section Nb 1902

Vt/Mtr 0.750 Kg

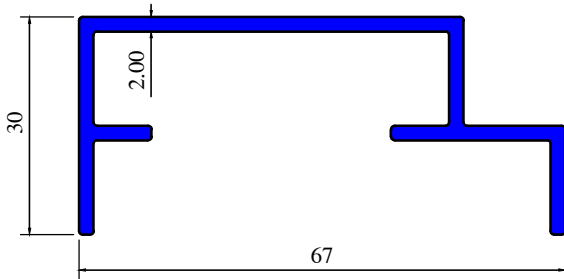

Section Nb 1915

Vt/Mtr 0.383 Kg

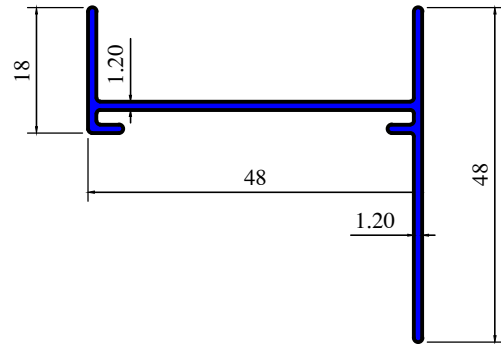

Section Nb 1903

Vt/Mtr 0.965 Kg

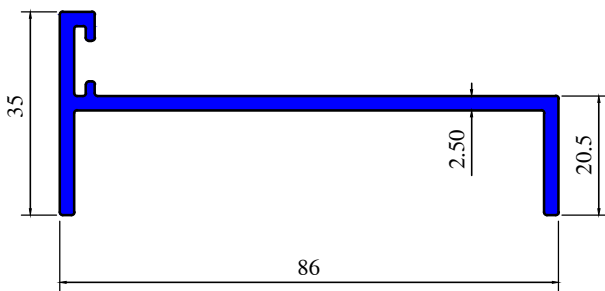

Section Nb 1904

Vt/Mtr 1.120 Kg

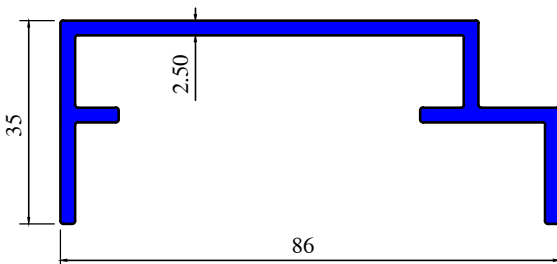



INDUSTRIAL SECTIONS

Section No. 1921

Wt/Mtr 0.180 kg

P60101

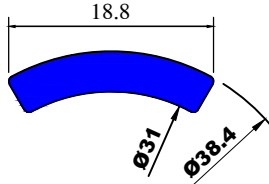

Section No. 1945

Wt/Mtr 2.988 kg

P60127

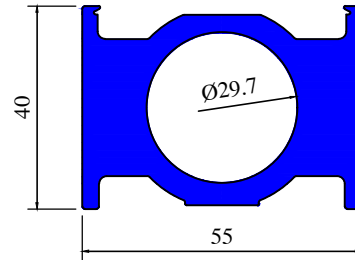

Section No. 1941

Wt/Mtr 13.764 kg

P60109

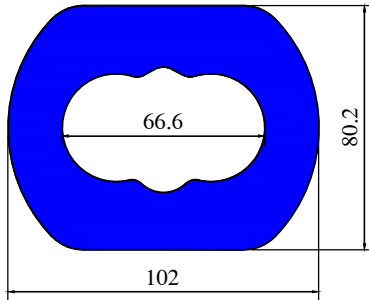

Section No. 1946

Wt/Mtr 2.183 kg

P60133

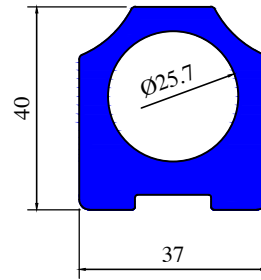

Section No. 1942

Wt/Mtr 4.491 kg

P60110

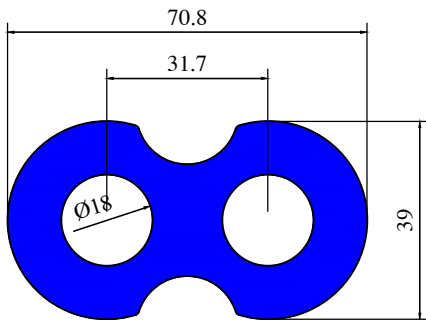

Section No. 1949

Wt/Mtr 2.721 kg

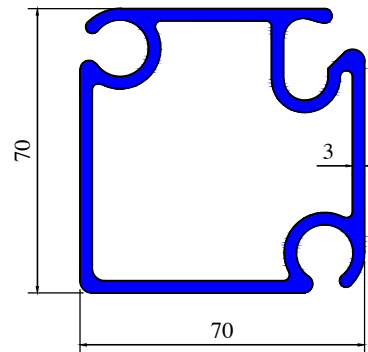

Section No. 1944

Wt/Mtr 2.129 kg

P60126

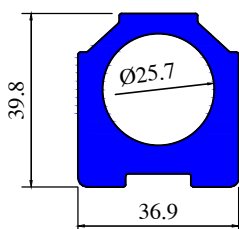

Section No. 1950

Wt/Mtr 0.385 kg

P60199

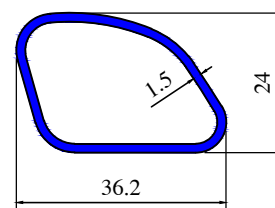



INDUSTRIAL SECTIONS

Section No. 1953 Wt/Mtr 0.671 kg Section No. 1960 Wt/Mtr 1.115 kg

P60204

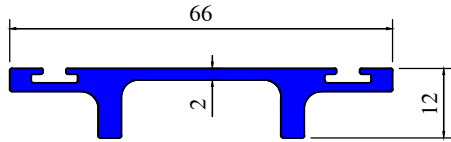

P60208

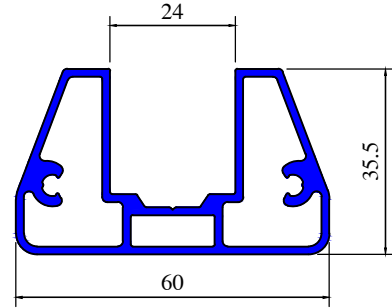

Section No. 1954 Wt/Mtr 1.066 kg Section No. 1961 Wt/Mtr 3.659 kg

P60205

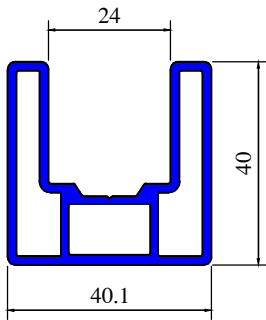

P60190

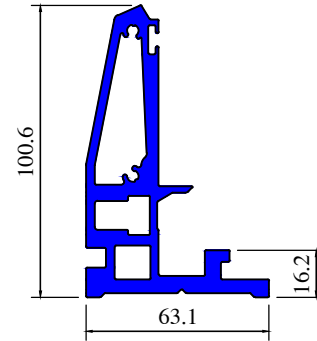

Section No. 1955 Wt/Mtr 1.069 kg Section No. 1962 Wt/Mtr 2.458 kg

P60206

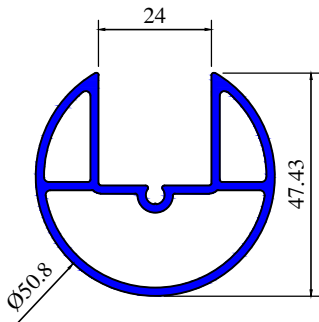

P60191

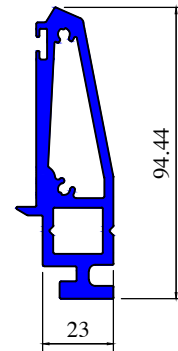

Section No. 1956 Wt/Mtr 0.481 kg Section No. 1963 Wt/Mtr 0.652 kg

P60207

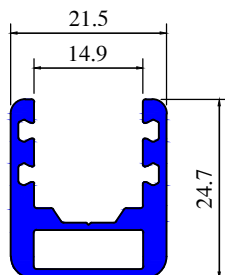

P60192

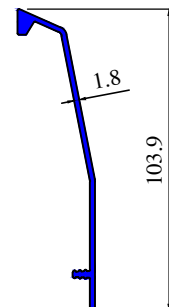



INDUSTRIAL SECTIONS

Section No. 1964

Wt/Mtr 5.639 kg

Section No. 1968

Wt/Mtr 5.457 kg

P60193

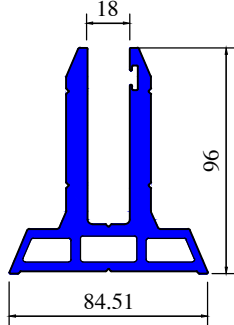

P60197

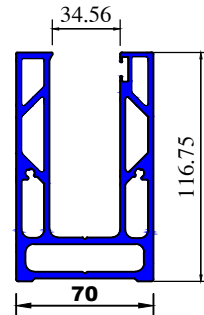

Section No. 1965

Wt/Mtr 3.120 kg

Section No. 1969

Wt/Mtr 0.166 kg

P60194

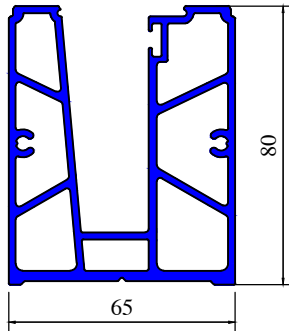

P60198

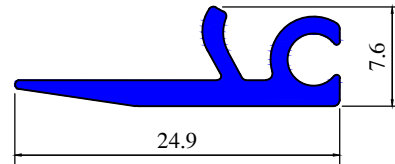

Section No. 1966

Wt/Mtr 0.199kg

Section No. 1970

Wt/Mtr 0.394 kg

P60195

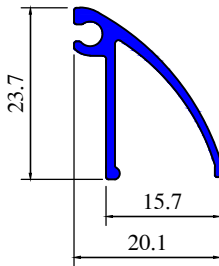

P60235

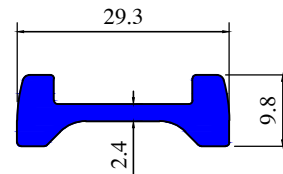

Section No. 1967

Wt/Mtr 2.054 kg

Section No. 1971

Wt/Mtr 0.223 kg

P60196

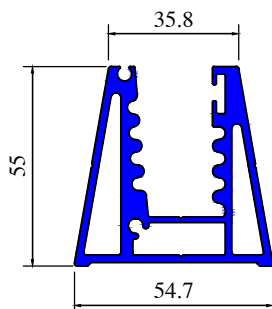

P60241

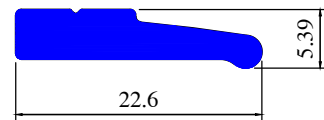



INDUSTRIAL SECTIONS

Section No. 1972

Wt/Mtr 0.103 kg

P60242

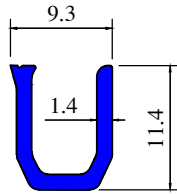

Section No. 1982

Wt/Mtr 1.018 kg

P60325

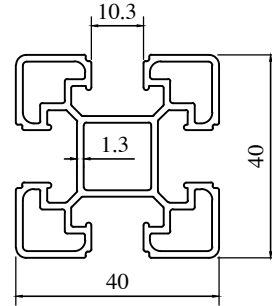

Section No. 1973

Wt/Mtr 0.352 kg

P60243

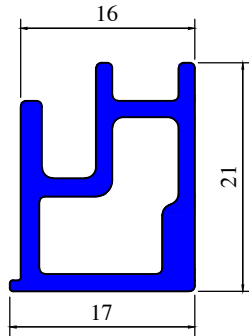

Section No. 1983

Wt/Mtr 3.093 kg

P60281

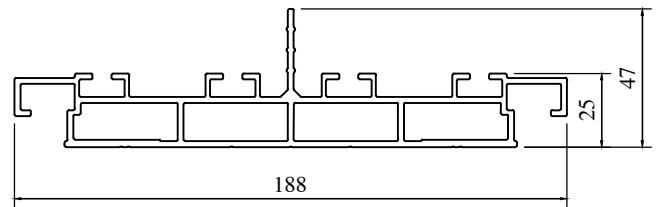

Section No. 1974

Wt/Mtr 2.181 kg

P60201

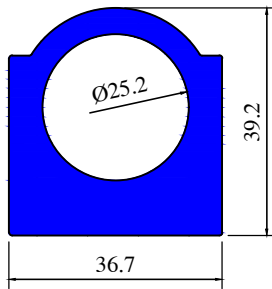

Section No. 1981

Wt/Mtr 14.401 kg

P60298

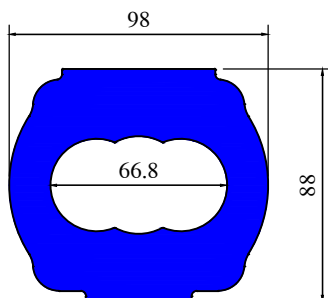



PADMAWATI EXTRUSION PVT. LTD.

5/2, Bharat Ashish Building, D.B. Gupta Road, Paharganj, New Delhi - 110055 (India)
+91 98999 07895, 98112 76191 | Email : info@padmawatiextrusion.com