



PADMAWATI  
EXTRUSION

CATALOGUE 2019

CURTAINWALL SECTION

**Padmawati Extrusion Pvt. Ltd.**, with over 2 decades of experience, with focus on customer need and commitment to **quality, perfection and innovation**, has become one of the leading nationwide providers of aluminium.

The company has been engaged in the complete process of extrusion, from technical sales advise, designing, testing to providing all ancillary, hardware fittings for system windows, glazing systems, exhibition systems and various products and caters to architects, contractors and designers from different sectors & industries.

With an eye on quality, the company has also introduced **aluminium profiles with scratch free sand blasted anodize finish, brush anodize finish, mirror finish and various powder coated finishes** for our discerning customers.

Our way of working reflects delivering an advantage in every key aspect of our business – sourcing, operations and cost. Basically, we are a **one stop shop for extruded aluminium** custom solutions for practically any application.





## CURTAINWALL SECTION

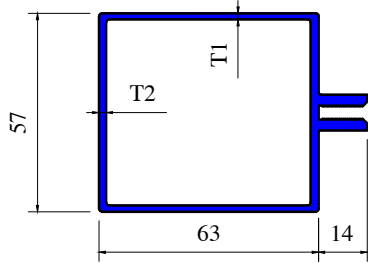

Section No	T1 (mm)	T2 (mm)	Wt/Mtr (Kgs)	Wt.Range (Kgs/12')
4530	1.5	1.50	1.166	
4503	1.8	2.00	1.474	

### Section No 4522

Wt/Mtr 1.688 Kg

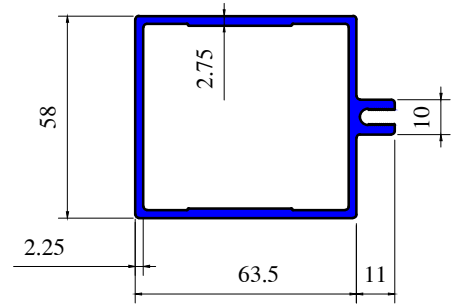

### Section No 4563

Wt/Mtr 2.43 Kg

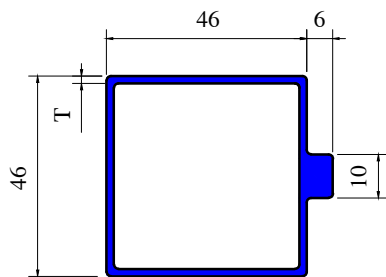
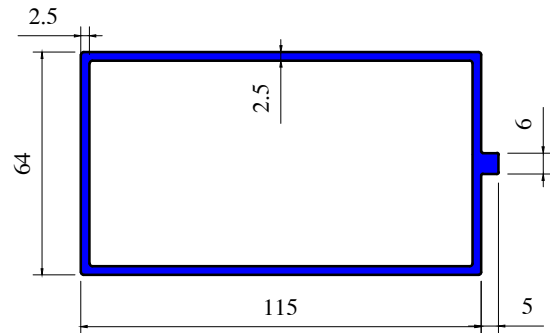

Section No	T (mm)	Wt/Mtr (Kgs)	Wt.Range (Kgs/12')
4531	1.05	0.621	2.20-2.50
4521	1.40	0.783	2.80-3.20
4520	1.70	0.923	3.20-3.60
4574	2.05	1.080	3.80 - 4.10

### Section No 4515

Wt/Mtr 0.988 Kg

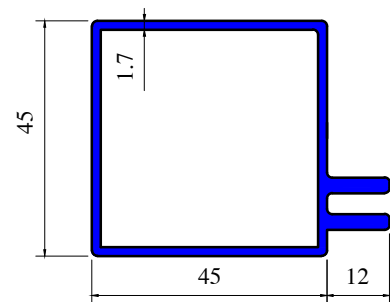

### Section No 4514

Wt/Mtr 0.988 Kg

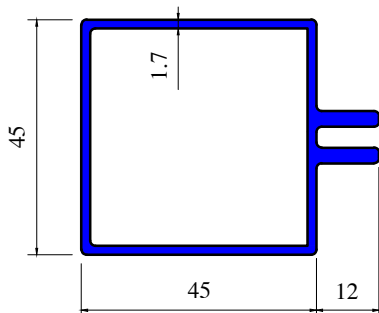



## CURTAINWALL SECTION

Section No 4519

Wt/Mtr 2.276 Kg

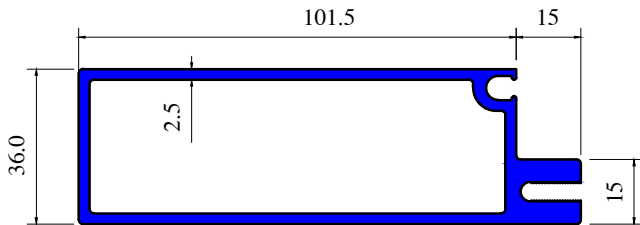

Section No 4502

Wt/Mtr 2.597 Kg

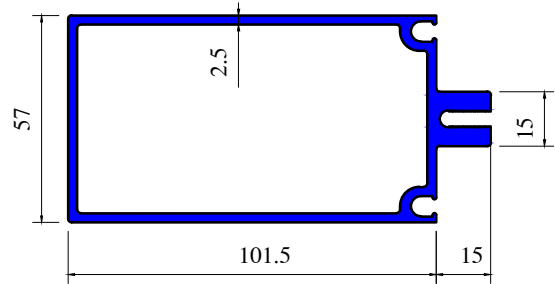

Section No 4501

Wt/Mtr 1.534 Kg

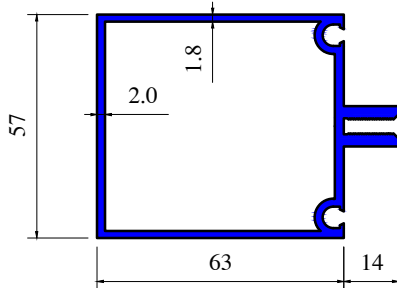

Section No 4523

Wt/Mtr 3.810 Kg

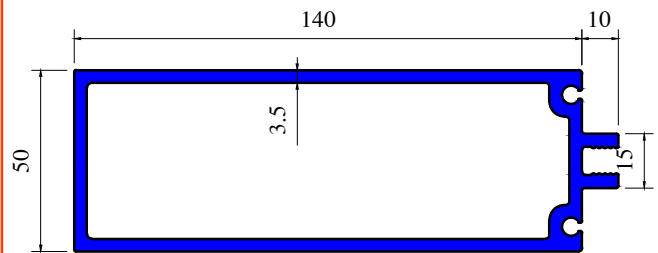

Section No 4532

Wt/Mtr 2.13 Kg

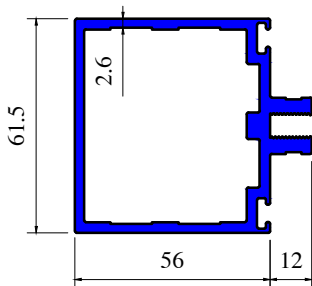

Section No 4524

Wt/Mtr 3.850 Kg

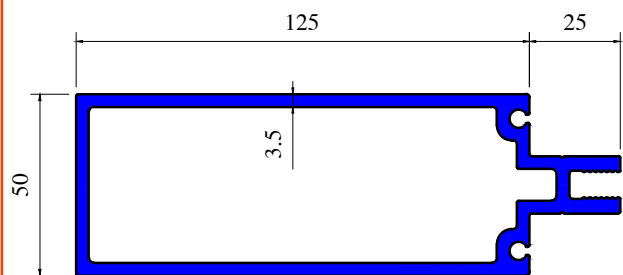

Section No 4566

Wt/Mtr 3.15 Kg

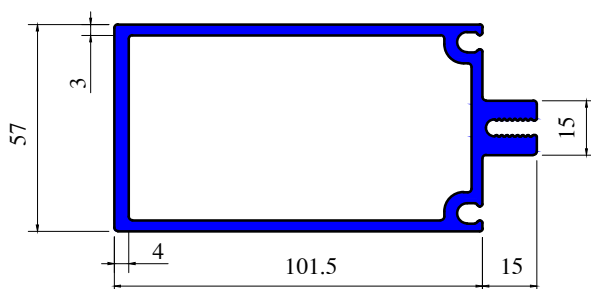

Section No 4527

Wt/Mtr 0.842 Kg

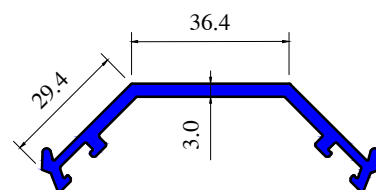



## CURTAINWALL SECTION

Section No 4567

Wt/Mtr 6.167 Kg

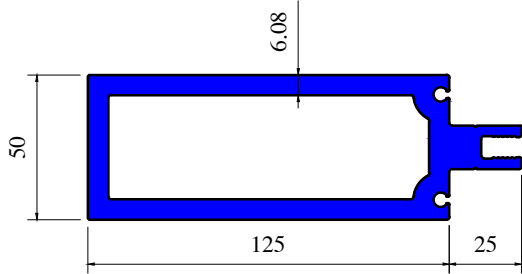

Section No 4568

Wt/Mtr 6.148 Kg

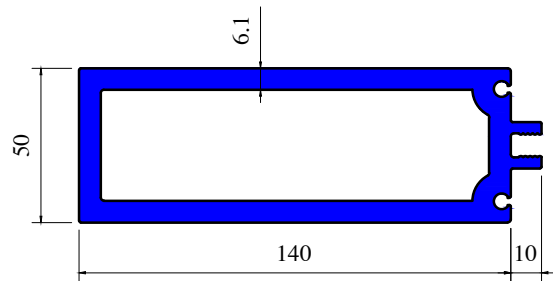

Section No 4571

Wt/Mtr 3.94 Kg

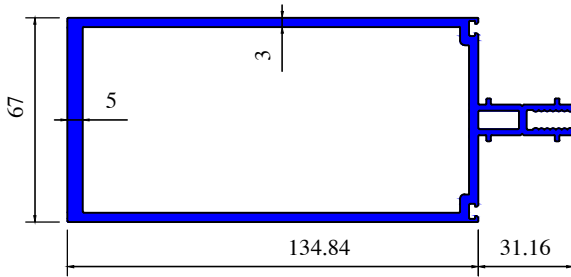

Section No 4572

Wt/Mtr 2.522 Kg

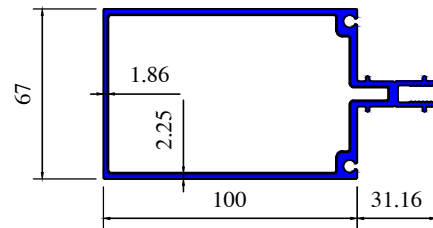

Section No 4573

Wt/Mtr 2.408 Kg

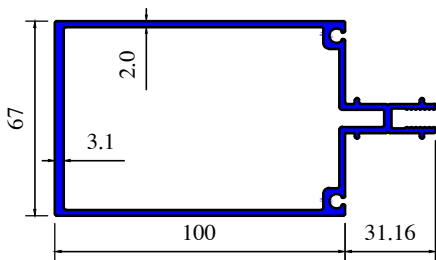

Section No 4575

Wt/Mtr 3.348 Kg

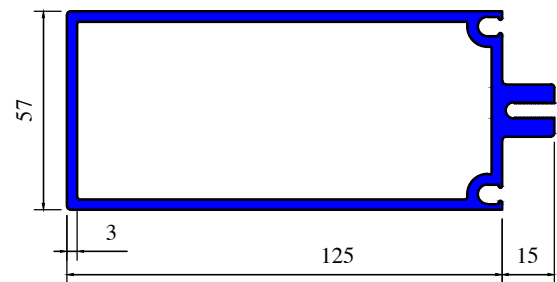

Section No 4576

Wt/Mtr 3.753 Kg

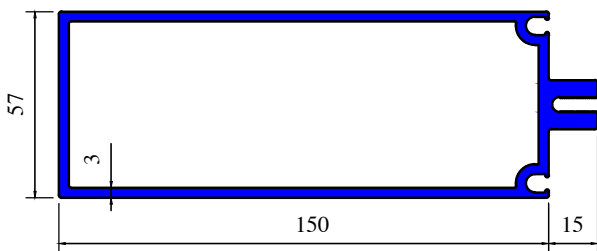

Section No 4592

Wt/Mtr 1.256 Kg

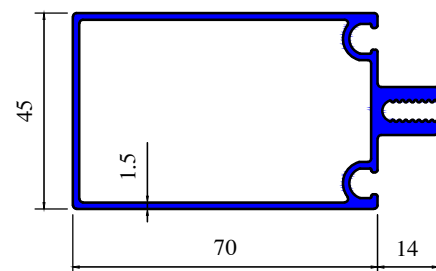



## CURTAINWALL SECTION

Section No 4581

Wt/Mtr 2.20 Kg

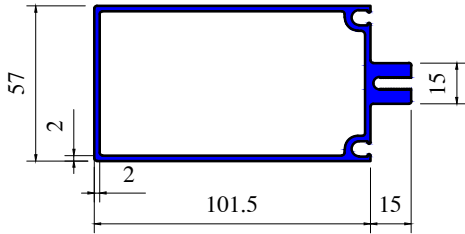

Section No 4582

Wt/Mtr 1.9 Kg

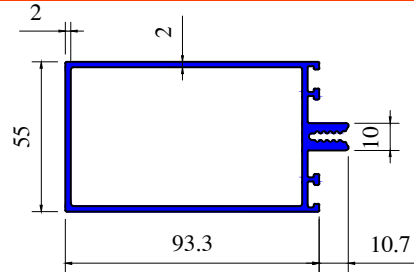

Section No 4583

Wt/Mtr 3.2 Kg

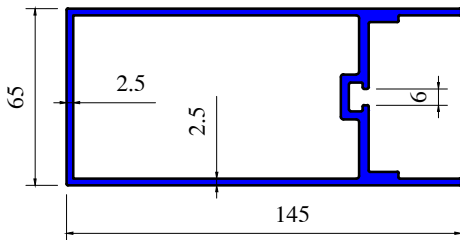

Section No 4584

Wt/Mtr 2.421 Kg

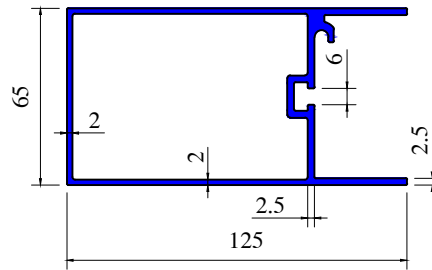

Section No 4585

Wt/Mtr 0.181 Kg

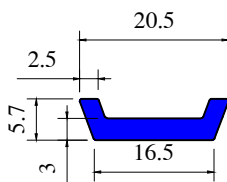

Section No 4586

Wt/Mtr 0.575 Kg

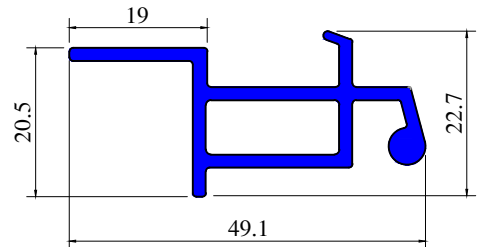

Section No 4587

Wt/Mtr 2.365 Kg

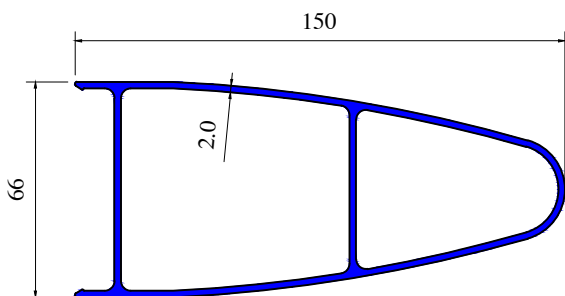

Section No 4589

Wt/Mtr 0.635 Kg

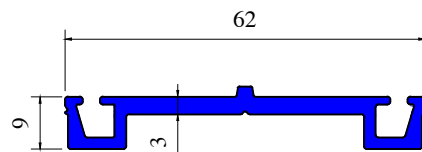



## CURTAINWALL SECTION

Section No 4588

Wt/Mtr 1.218 Kg

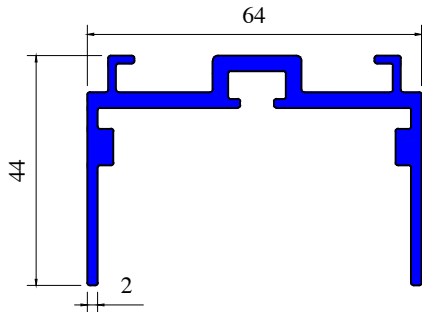

Section No 4591

Wt/Mtr 2.114 Kg

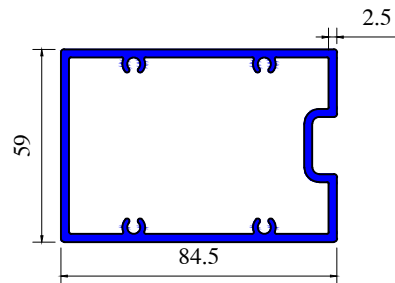

Section No 4593

Wt/Mtr 4.668 Kg

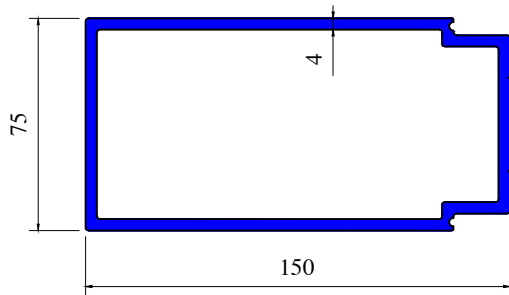

Section No 4594

Wt/Mtr 2.954 Kg

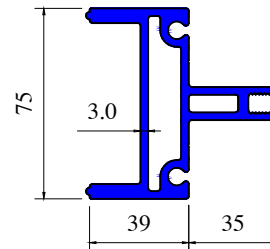

Section No 4595

Wt/Mtr 0.645 Kg

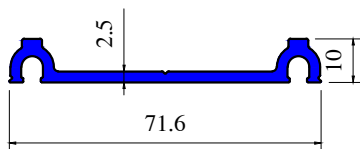

Section No 4596

Wt/Mtr 0.437 Kg

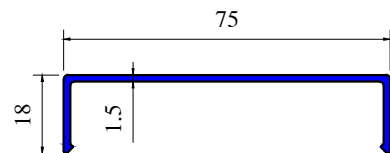

Section No 4548

Wt/Mtr 0.246 Kg

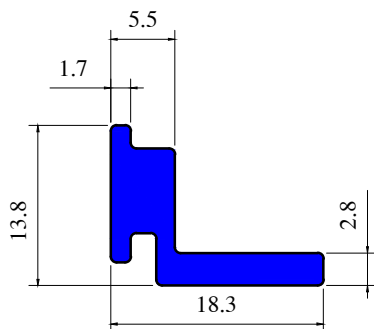

Section No 4590

Wt/Mtr 0.435 Kg

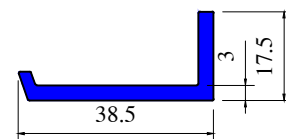



## CURTAINWALL SECTION

Section No 4529

Wt/Mtr 3.20 Kg

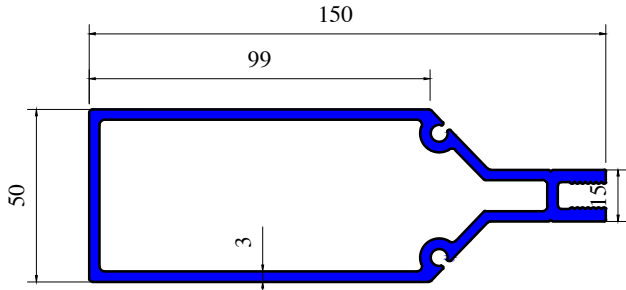

Section No 4569

Wt/Mtr 2.81 Kg

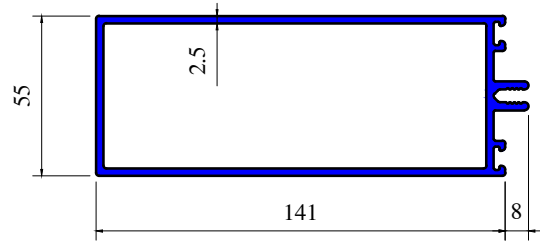

Section No 4525

Wt/Mtr 0.510 Kg

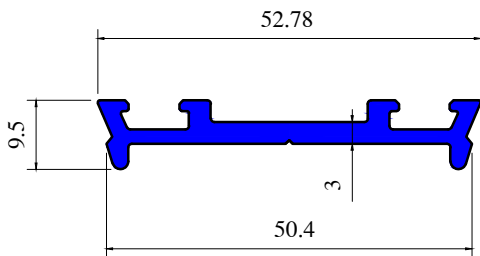

Section No 4526

Wt/Mtr 0.345 Kg

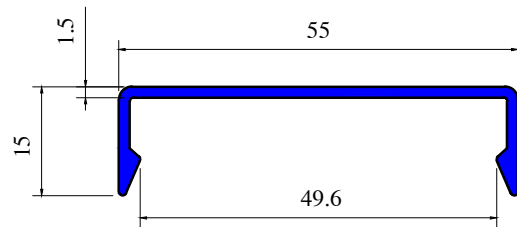

Section No 4528

Wt/Mtr 0.505 Kg

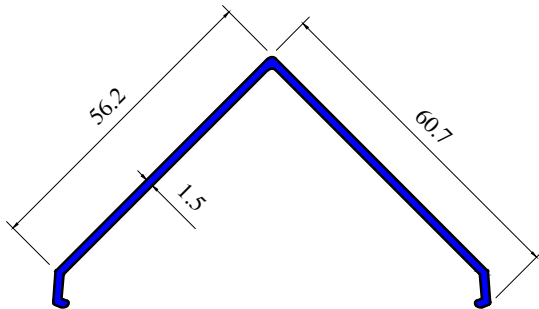

Section No 4597

Wt/Mtr 0.575 Kg

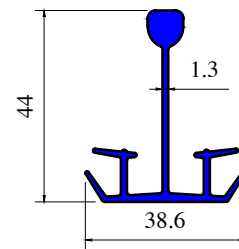

Section No 4598

Wt/Mtr 0.672 Kg

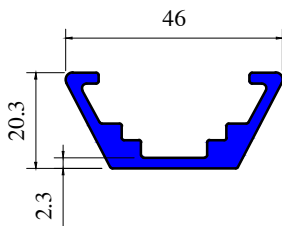

Section No 4599

Wt/Mtr 0.375 Kg

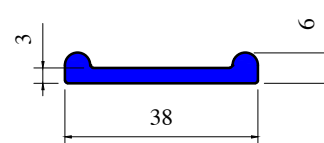





## CURTAINWALL SECTION

Section No 4513

Wt/Mtr 0.653 Kg

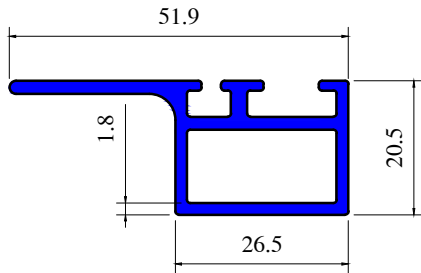

Section No 4518

Wt/Mtr 0.508 Kg

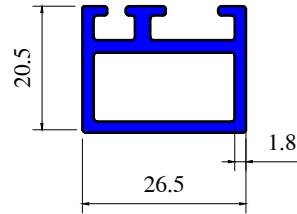

Section No 4504

Wt/Mtr 0.456 Kg

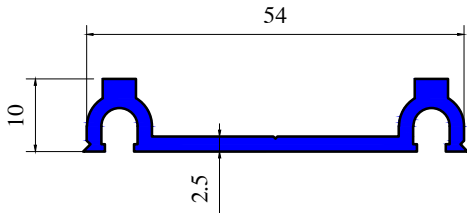

Section No 4505

Wt/Mtr 0.27 Kg

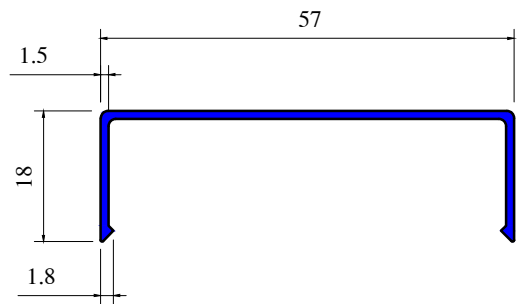

Section No 4580

Wt/Mtr 1.306 Kg

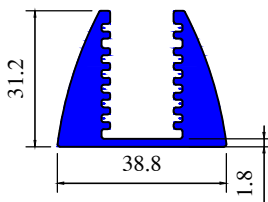

Section No 4577

Wt/Mtr 0.386 Kg

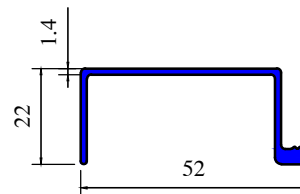

Section No 4578

Wt/Mtr 0.294 Kg

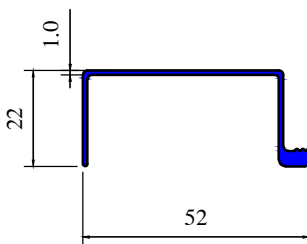

Section No 4579

Wt/Mtr 0.416 Kg

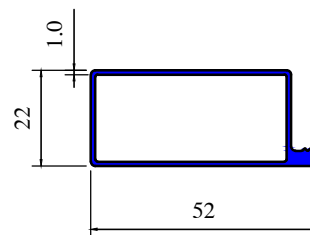



## CURTAINWALL SECTION

Section No 4508

Wt/Mtr 2.61 Kg

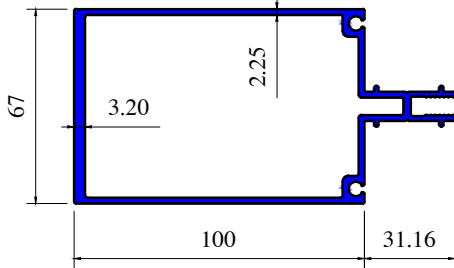

Section No 4507

Wt/Mtr 1.887 Kg

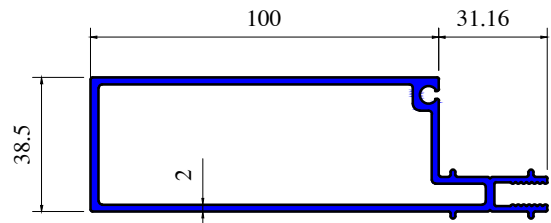

Section No 4506

Wt/Mtr 2.7 Kg

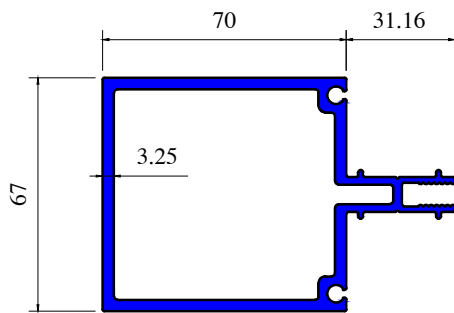

Section No 4510

Wt/Mtr 1.595 Kg

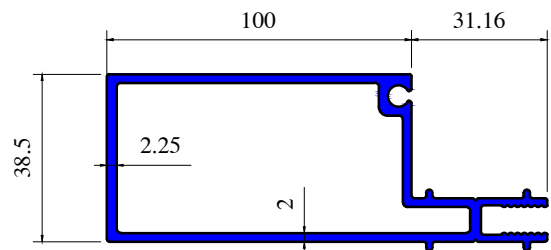

Section No 4509

Wt/Mtr 1.682 Kg

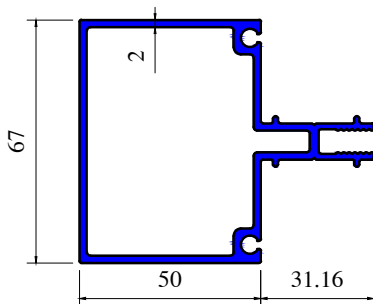

Section No 4517

Wt/Mtr 1.320 Kg

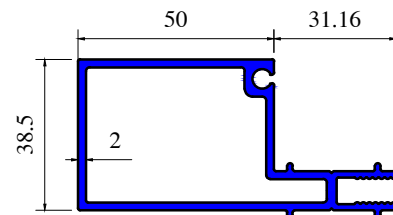

Section No 4565

Wt/Mtr 3.164 Kg

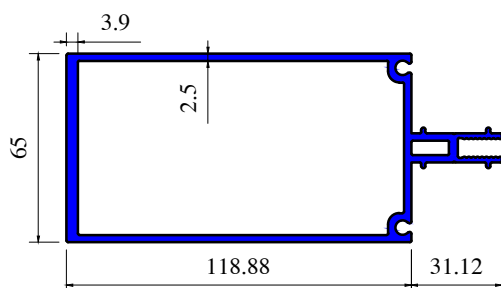

Section No 4570

Wt/Mtr 2.873 Kg

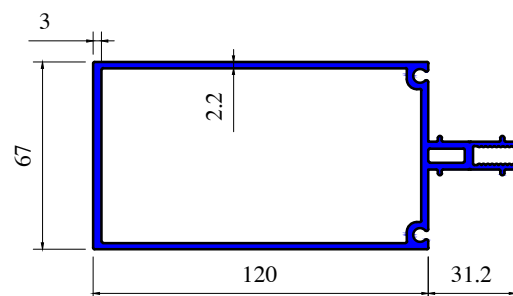



## CURTAINWALL SECTION

Section No 4560

Wt/Mtr 1.95 Kg

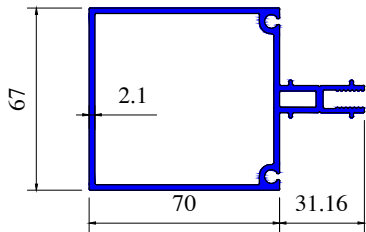

Section No 4564

Wt/Mtr 2.543 Kg

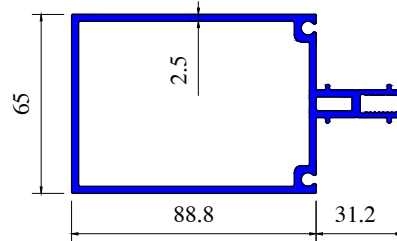

Section No 4550

Wt/Mtr 1.490 Kg

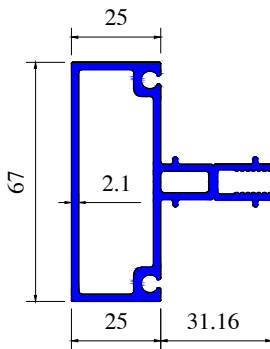

Section No 4549

Wt/Mtr 0.221 Kg

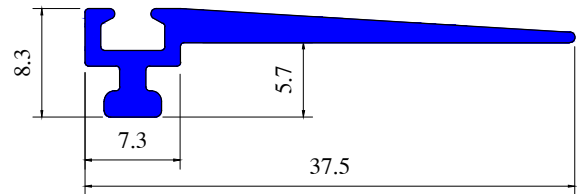

Section No 4555

Wt/Mtr 0.289 Kg

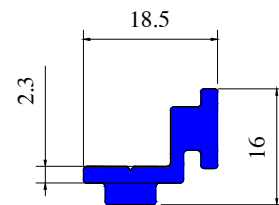

Section No 4539

Wt/Mtr 0.240 Kg

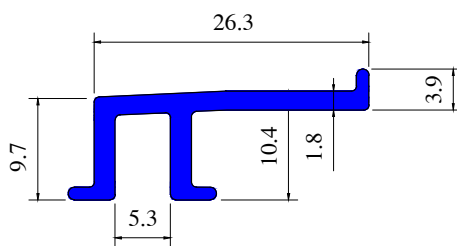

Section No 4512

Wt/Mtr 0.199 Kg

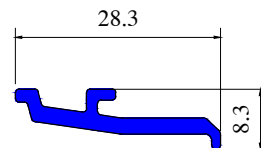

Section No 4516

Wt/Mtr 0.937 Kg

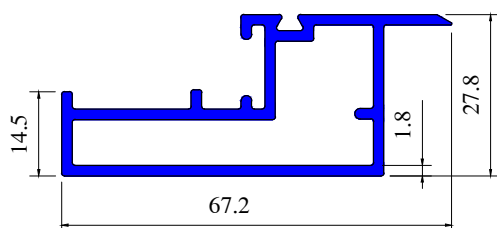

Section No 4538

Wt/Mtr 1.026 Kg

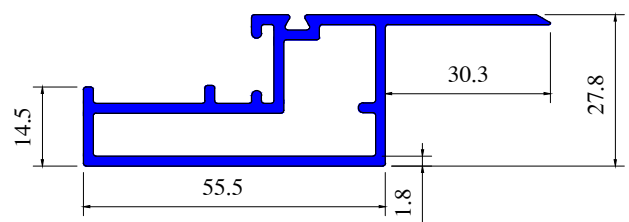



## CURTAINWALL SECTION

Section No 4562

Wt/Mtr 0.651 Kg

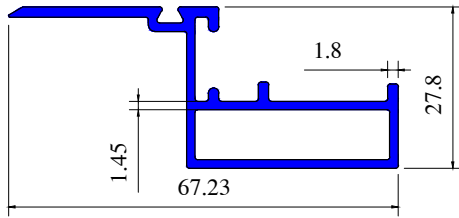

Section No 4561

Wt/Mtr 0.775 Kg

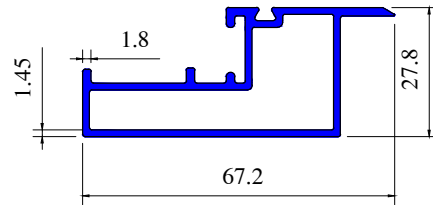

Section No 4511

Wt/Mtr 0.532 Kg

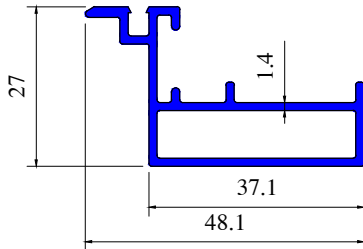

Section No 4551

Wt/Mtr 0.454 Kg

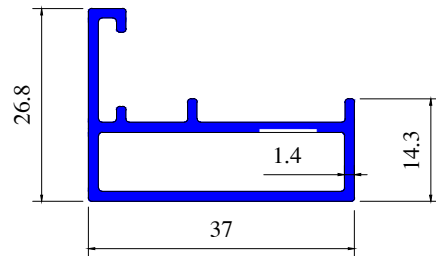

Section No 4552

Wt/Mtr 0.365 Kg

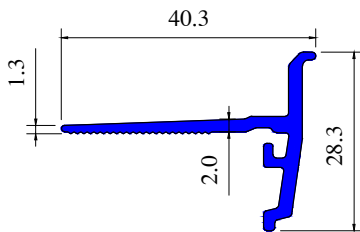

Section No 4546

Wt/Mtr 1.401 Kg

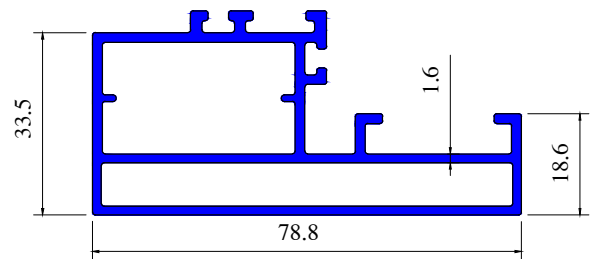

Section No 4547

Wt/Mtr 1.002 Kg

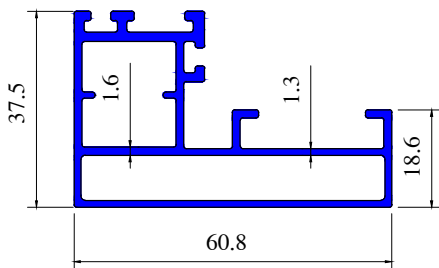

Section No 4557

Wt/Mtr 0.886 Kg

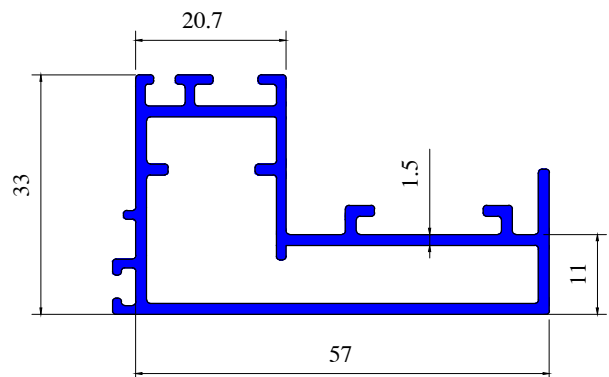

Section No 4554

Wt/Mtr 0.816 Kg

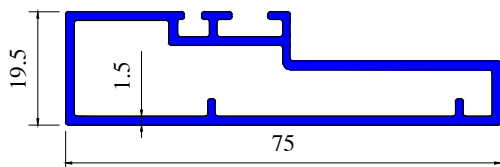



## CURTAINWALL SECTION

Section No 4541

Wt/Mtr 3.196 Kg

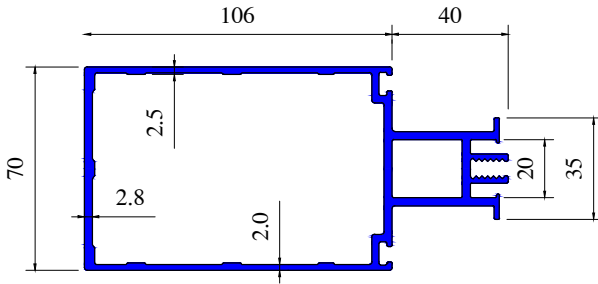

Section No 4543

Wt/Mtr 1.73 Kg

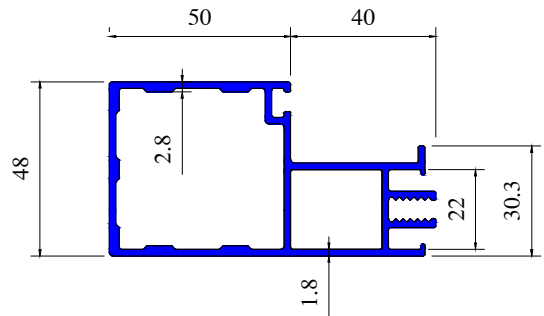

Section No 4542

Wt/Mtr 2.80 Kg

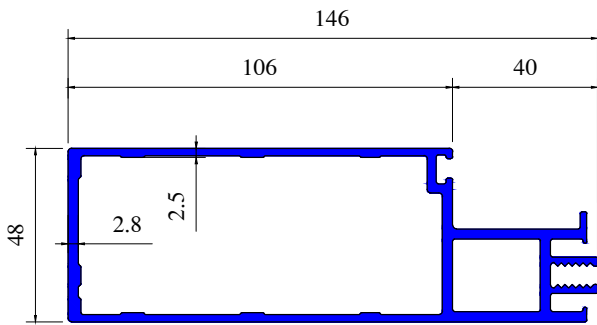

Section No 4540

Wt/Mtr 2.01 Kg

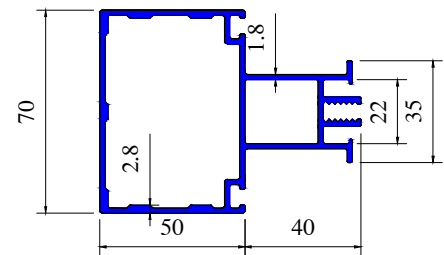

Section No 4556

Wt/Mtr 1.660 Kg

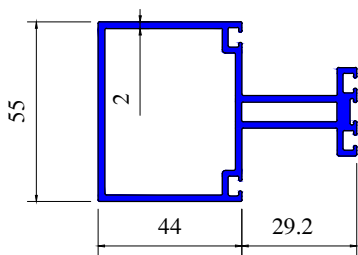

Section No 4558

Wt/Mtr 2.810 Kg

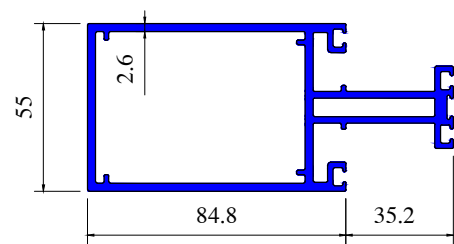

Section No 4559

Wt/Mtr 2.28 Kg

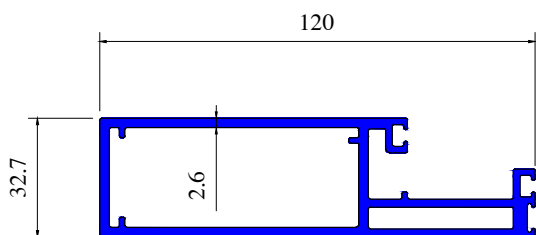

Section No 4553

Wt/Mtr 0.650 Kg

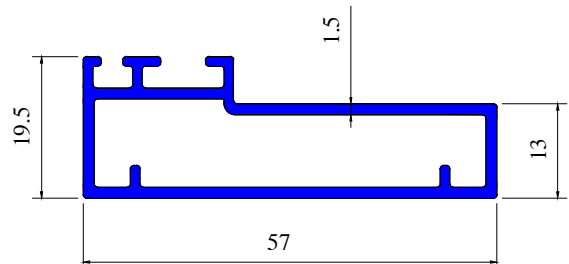



## CURTAINWALL SECTION

Section Nb 4049

Wt/Mtr 2.344 Kg

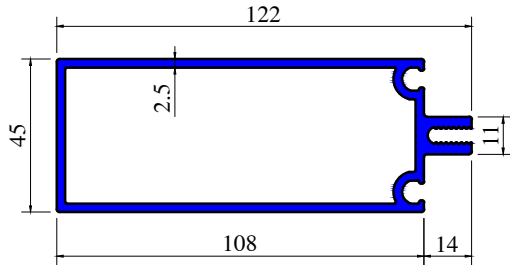

Section Nb 4050

Wt/Mtr 1.984 Kg

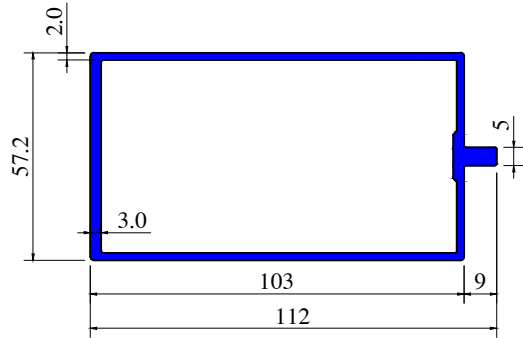

Section Nb 4051

Wt/Mtr 1.442 Kg

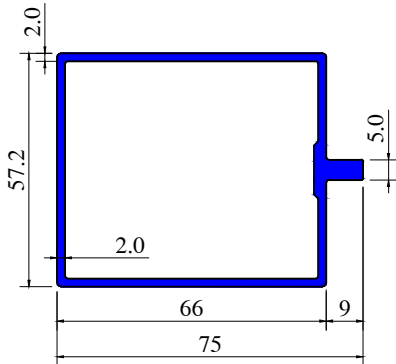

Section Nb 4052

Wt/Mtr 1.460 Kg

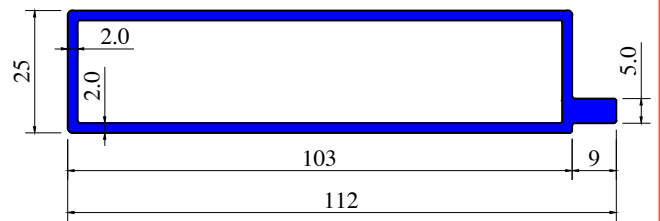

Section Nb 4053

Wt/Mtr 0.254 Kg

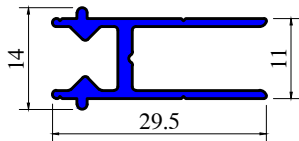

Section Nb 4054

Wt/Mtr 1.070 Kg

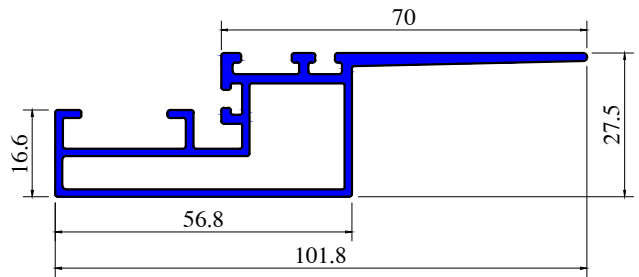

Section Nb 4055

Wt/Mtr 1.112 Kg

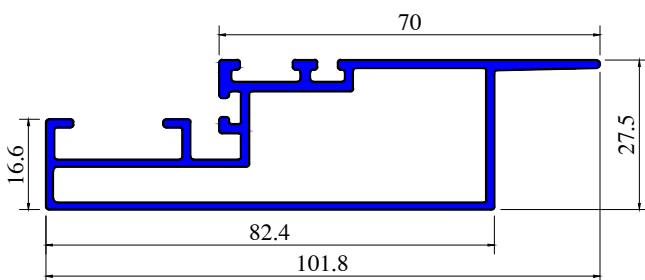

Section Nb 4056

Wt/Mtr 0.181 Kg

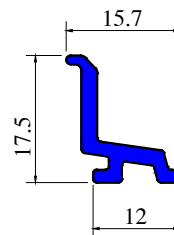



## CURTAINWALL SECTION

Section Nb 4057

Vt/Mtr 0.896 Kg

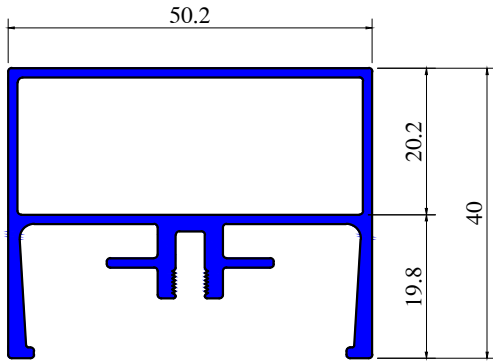

Section Nb 4058

Vt/Mtr 0.640 Kg

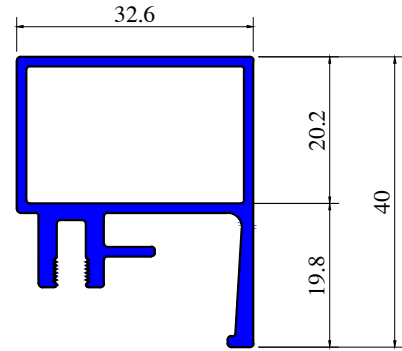

Section Nb 4059

Vt/Mtr 0.321 Kg

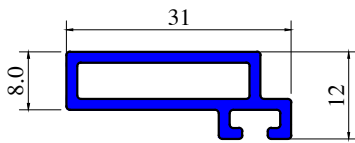

Section Nb 4060

Vt/Mtr 0.302 Kg

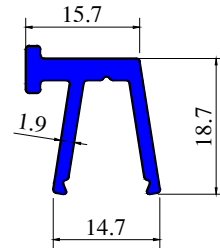

Section Nb 4061

Vt/Mtr 0.127 Kg

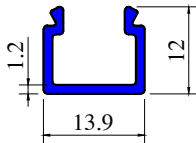

Section Nb 4062

Vt/Mtr 1.110 Kg

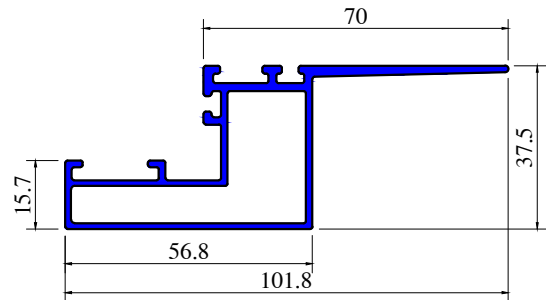

Section Nb 4068

Vt/Mtr 6.197 Kg

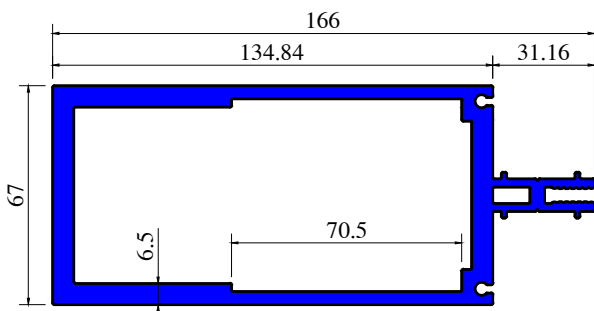

Section Nb 4069

Vt/Mtr 1.377 Kg

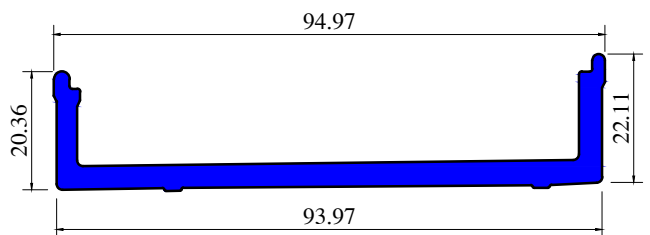



## CURTAINWALL SECTION

Section Nb 4070

Vt/Mtr 0.070 Kg

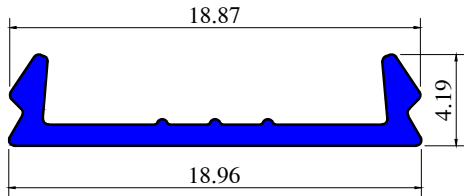

Section Nb 4071

Vt/Mtr 0.494 Kg

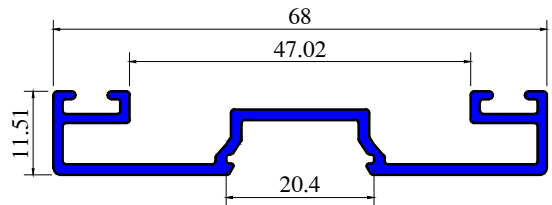

Section Nb 4072

Vt/Mtr 0.626 Kg

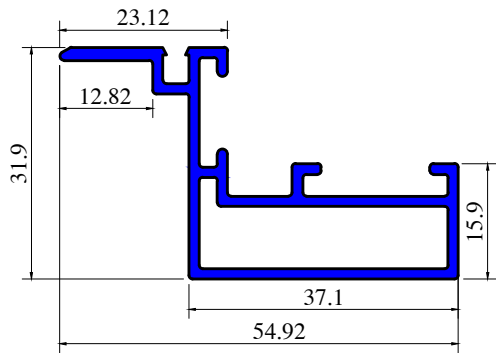

Section Nb 4074

Vt/Mtr 1.239 Kg

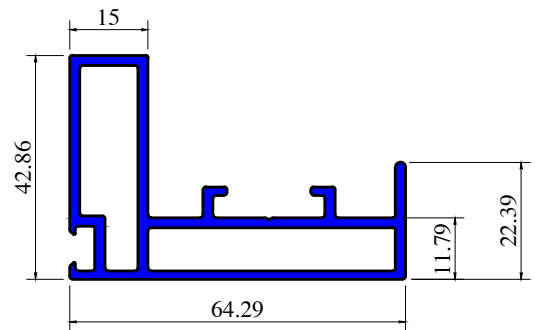

Section Nb 4075

Vt/Mtr 1.601 Kg

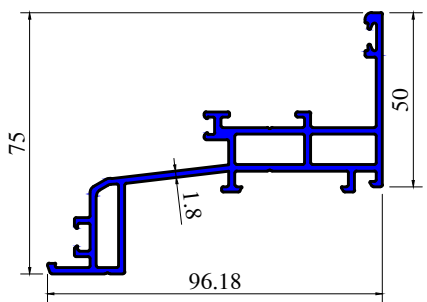

Section Nb 4078

Vt/Mtr 0.680 Kg

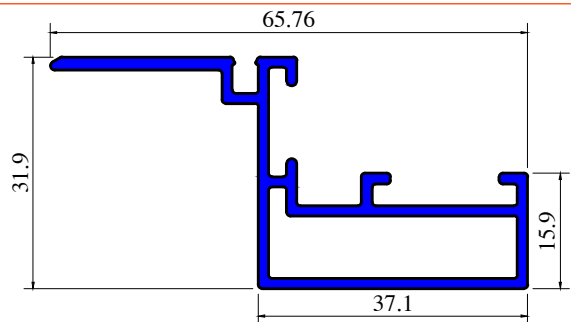

Section Nb 4080

Vt/Mtr 2.716 Kg

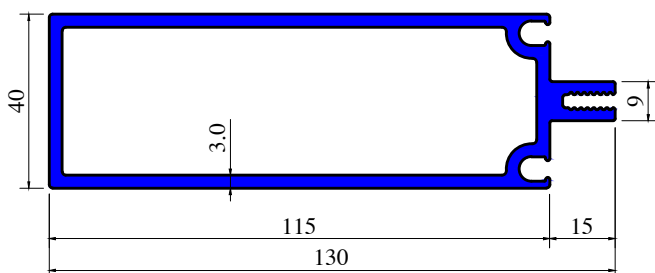

Section Nb 4081

Vt/Mtr 0.400 Kg

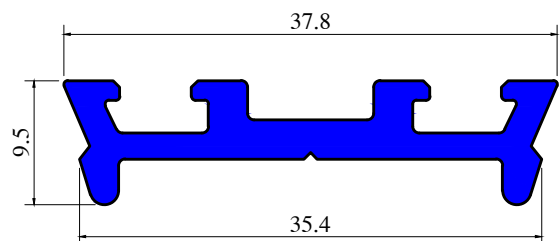





**CURTAINWALL SECTION**

Section Nb 4082

Vt/Mtr 0.286 Kg

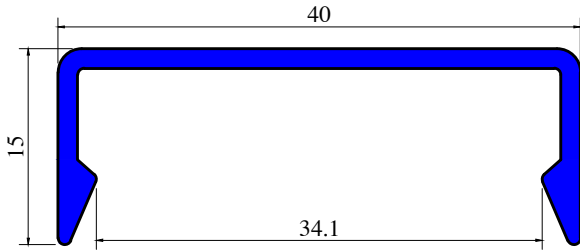

Section Nb A8467

Vt/Mtr 2.811 Kg

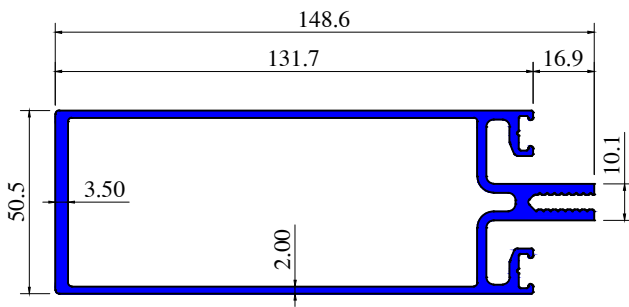



## CURTAINWALL SECTION

Section No. 4088

Wt/Mtr 5.900 kg

P60215

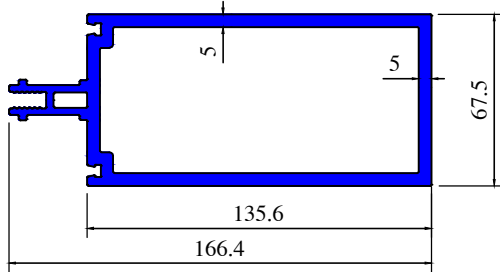

Section No. 4094

Wt/Mtr 3.783 kg

P60285

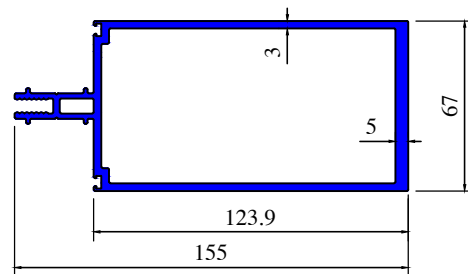

Section No. 4090

Wt/Mtr 3.048 kg

P60238

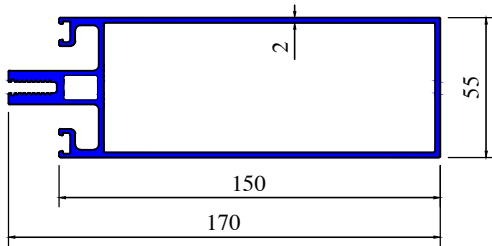

Section No. 4095

Wt/Mtr 2.979 kg

P60286

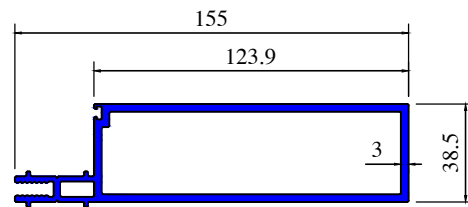

Section No. 4091

Wt/Mtr 2.021 kg

P60239

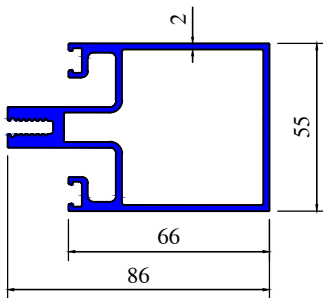

Section No. 4096

Wt/Mtr 2.061 kg

P60288

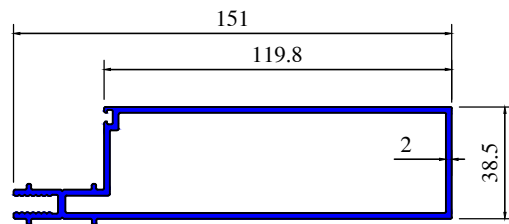

Section No. 4092

Wt/Mtr 3.351 kg

P60263

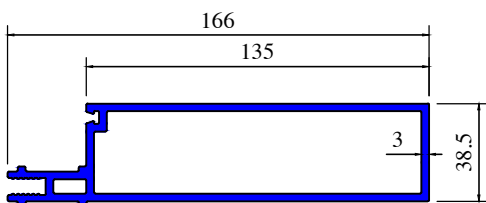



**PADMAWATI EXTRUSION PVT. LTD.**

5/2, Bharat Ashish Building, D.B. Gupta Road, Paharganj, New Delhi - 110055 (India)  
+91 98999 07895, 98112 76191 | Email : [info@padmawatiextrusion.com](mailto:info@padmawatiextrusion.com)